

2016 nov. 12th

The Janus Cosmological Model.

Fourty years of work



J.P.Petit¹

The Janus cosmological model is the result of 40 years of work. Let me tell you that story.

In 1967 the Russian Andrei Sakharov published a very exotic work, presenting a theory of the twin universe ([1] , [2] , [3]). This work remained ignored during a long time.

Personally, I discovered his theory about « twin universe » in 1984, seven years after my first publications on the subject (1977) issued ten years after his papers published in russian (1967). Presently we are the only scientists who paid attention to this idea, possibly because we had the same source of inspiration.

Sakharov suggests that the universe is composed by two entities, he calls twin universes. One is the universe that we know, made of matter. The second is its twin universe, made of twin matter. The two are linked through the Big Bang singularity. Immediatley we find a puzzling feature.

¹ jp.petit@mailaps.org

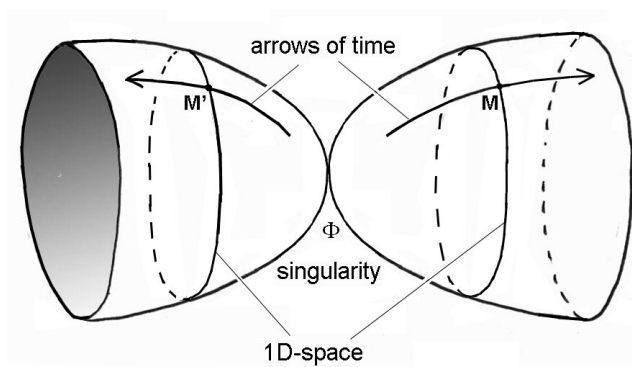

Fig.1 : 2D didactic image of Sakharov's twin universe model

Il these two folds of the universe the arrows of time are opposite ! Moreover, the two folds are enantiomorphic, mirror-symmetric. Next, a classical example of mirror-symmetry :



Fig.2 : Enantiomorphic corkscrews

What would it mean, from a cosmological point of view? For example: two enantiomorphic particles would be identical, except the orientation of their spins. Enantiomorphic particles would have opposite spins.

Have a look to the Janus god. I have discovered very recently that this god looks towards the future and towards the past, simultaneously.

By the way, this is the cover of the book published in 1984 (french issues) which contains collected works of A.Sakharov :

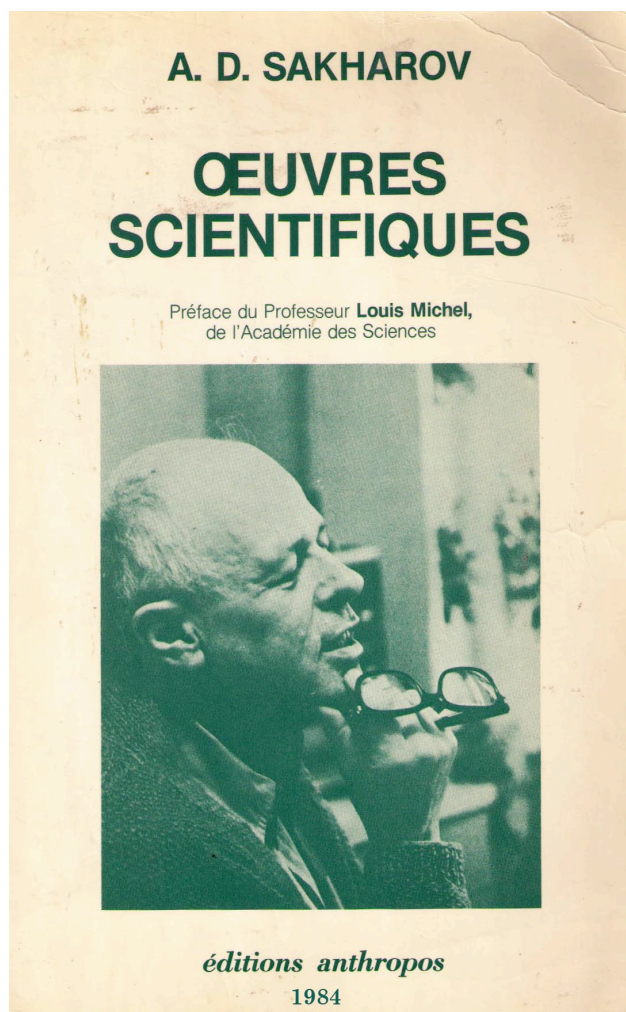

Fig.3 : A. Sakharov, collected works, french issue, 1984

Sakharov gives no explanation about such hypothesis. What is his leading idea ?

You probably know that the absence of primeval antimatter in our universe is one of the most puzzling problem in science. Consider the Big Bang model. You may have a look to the comic book entitled Big Bang, I published in 1994 on the subject at, the following URL :

http://www.savoir-sans-frontieres.com/JPP/telechargeables/English/big_bang.htm

On page 22 :

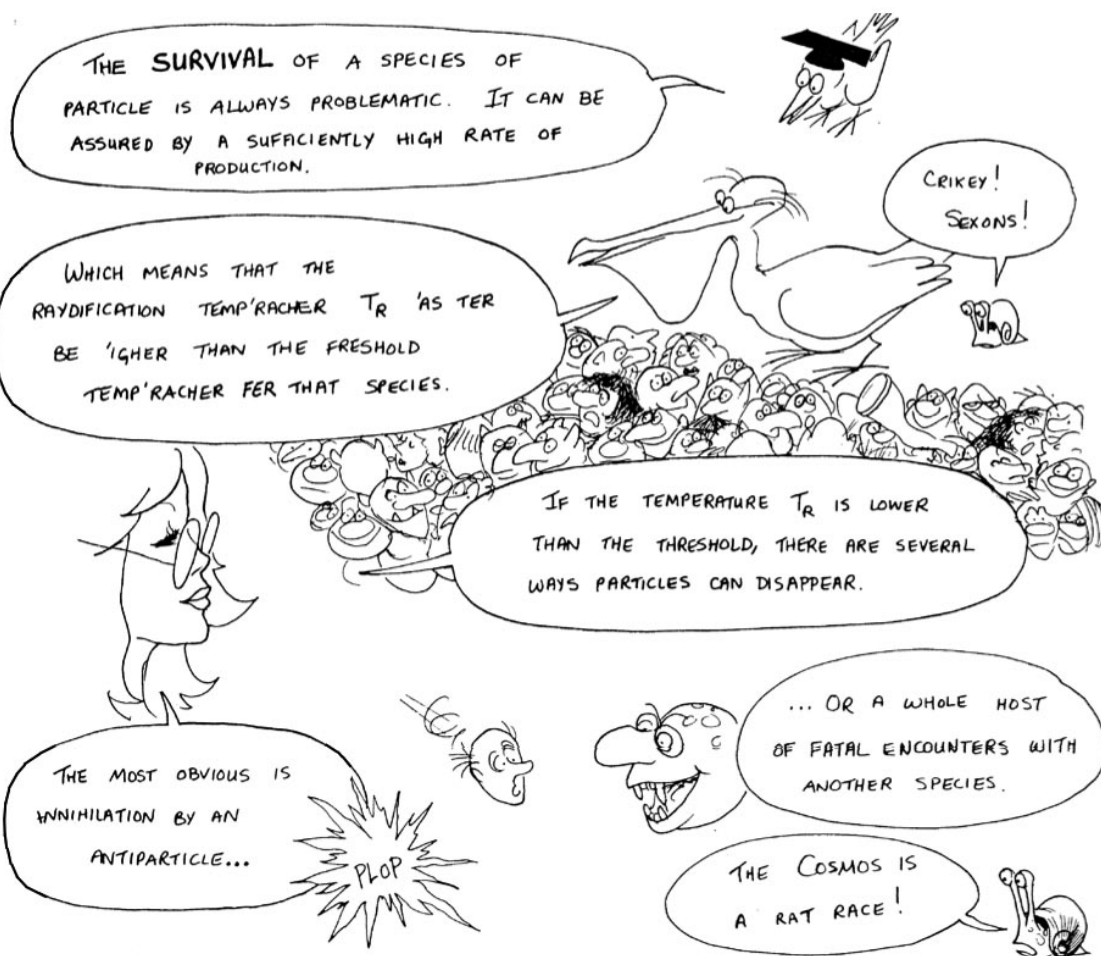

When the temperature of the cosmic soup falls down the annihilation process can no longer be balanced by the creation of pairs matter-antimatter, so that the (positive mass) components tend to completely disappear, replaced by photons. Only one part among a billion survives.

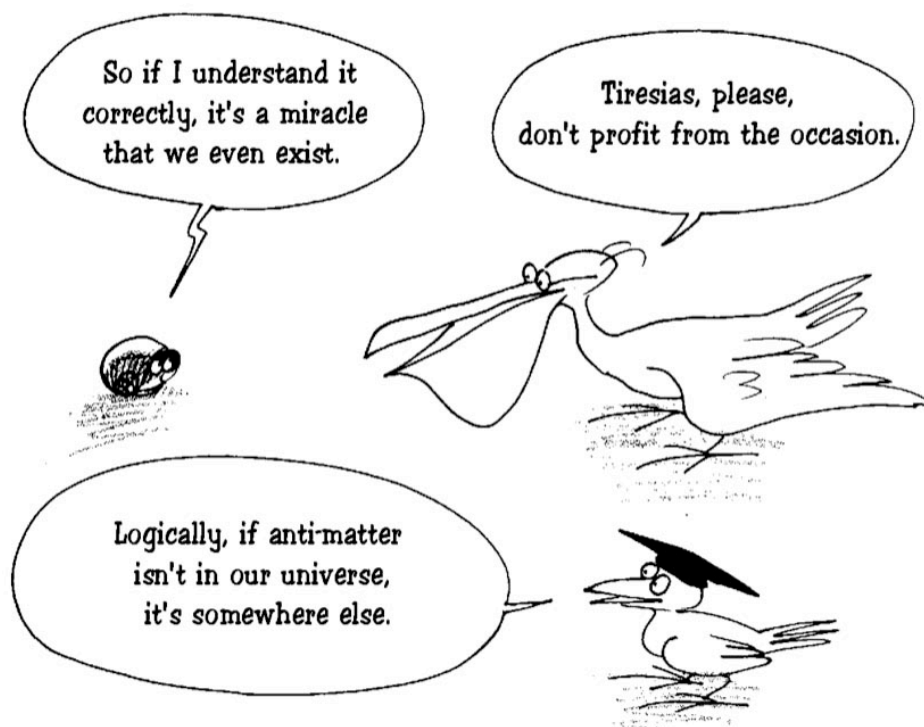

Why? This is an unsolved mystery. By the way, if that part of matter corresponding to one part of one per billion survives, where is the corresponding part of antimatter?

Decades ago some scientists suggested that, among the observed galaxies some could be made of matter and some others of antimatter. But the observation showed that, due to the random movements of galaxies in clusters, collisions occur. If a single collision of a galaxy and an anti-galaxy would occur, even at very large distance, the flux of hard gamma rays would be so intense that it would have been detected on Earth.

As such gamma flux was not evidenced it became evident that the half part of the Universe was missing.

Sakharov suggested in 1967 that the rate of production of baryons (protons, neutrons) from quarks would have been, in our fold of the universe, slightly higher than the rate of production of antibaryons (antiprotons, antineutrons) from antiquarks.

Conversely : inverse situation in the « twin universe ». As a result :

In our universe, we would find :

- photons, as a result of annihilations matter-antimatter
- remnant matter (observed)
- plus the corresponding leftover of antiquarks (ratio 3 to 1, because 3 antiquarks are required to make an antibaryon)

In the twin universe :

- « twin photons », as a result of annihilations twin matter- twin antimatter
- remnant « twin antimatter »

- plus the corresponding leftover of « twin quarks » (ratio 3 to 1).

Presently this (vague) idea of A.Sakharov is the only one available to try to explain the absence of observation of the primeval antimatter. The question is so embarrassing that the scientific community keeps silent about it.

Today, if somebody would like to organize an international conference about it and publishes a call for papers, no papers would be available.

To sum up :

Lost, half part of the universe

Good reward for any information which would help its capture !

That was the starting point of A.Sakharov, but it does not explain why he decided that his twin universe would be enatiomorphic and equipped with a reversed arrow of time.

In his papers ([1] , [2] , [3]) he introduces a link through the Big Bang singularity and suggests that black holes could possibly link the two folds.

I started to work on the question of twin universes in 1975 and published three papers in 1977 thanks to a french academician and mathematician, the professor André Lichnérowicz. This is a picture I made of him.



Fig.3 : Pr. A. [Lichnérowicz](#), collected works, 1915-1998

In 1958 I attended the french Ecole Supérieure de l'Aéronautique de Paris (Aeronautical school). After such studies and military service I tried during several years to live from art :

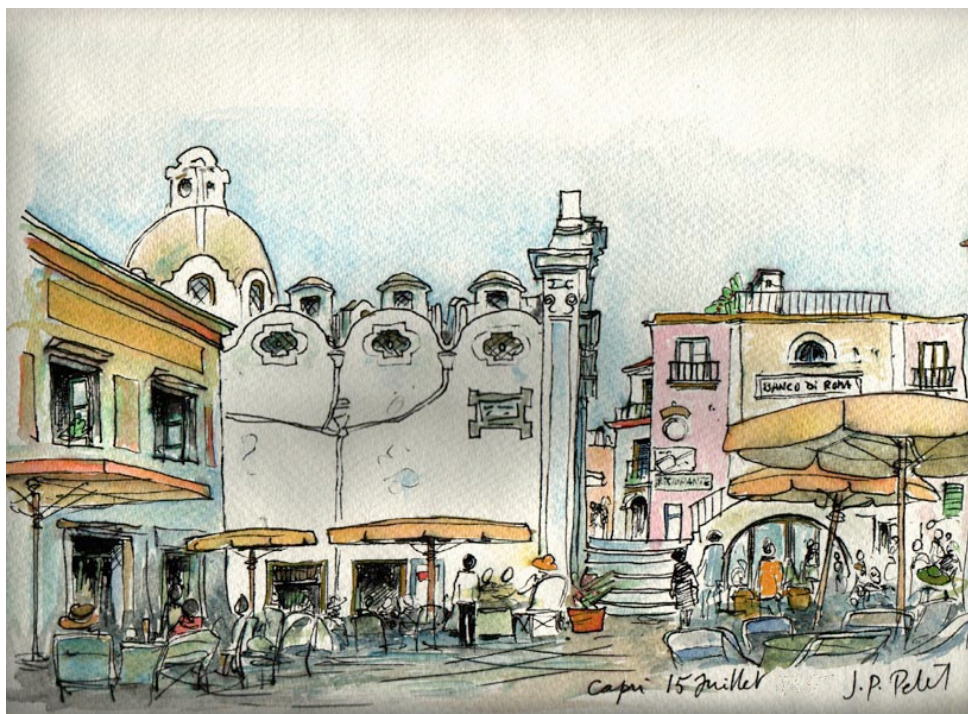

Fig.4 : Italia : Capri island, watercolour

As it did not work I went back to science. I worked on MHD power plants and invented the first technique to cancel the [electrothermal instability](#). When France gave up MHD I shifted to pure theory through kinetic theory of gases and Boltzmann equation. Finally, changing particles into stars, I shifted to galactic dynamics.

This last part would deserve another paper. If interested you can download a communication at an international meeting, held at IHES in 1974 :

<http://www.jp-petit.org/ihes1974>

Let's get back to cosmology.

Newtonian version of the Janus model

In 1977 I built an exact solution of a system of two Vlasov equations, coupled by Poisson equation. That was made possible with :

- two opposite times
- opposite electric charges
- enantiomorphy.

The three papers may be downloaded at :

<http://www.jp-petit.org/cras1977>

With respect to the model of Andrei Sakharov (that I discovered in 1984) the two entities were at once interacting.

That was very interesting ([4], [5], [6]) and was the beginning of my strong interest in cosmology. It took some time to extend the work to the relativistic field. And it took more time too succeed to publish this work in scientific journals.

Introducing variable speed of light

In 1998 I published another work [8] , in order to concretize the idea of a variable speed of light over the evolution of the universe. In effect classical cosmology brings a paradox, called « the paradox of the cosmological horizon ». This one arose when images of the primeval universe were captured by the satellite Cobe, in 1989. My work, 1988, solved the paradox. It may seem strange that the solution was found before the emergence of the problem. I confess I feel it strange too.

In spite of this logical strangeness, let us present the problem.

Due to the redshift the farther the source the larger the wavelength, so that if you use an instrument (an antenna) designed to capture very large wavelengths the nearby sources, like stars, galaxies, will simply be ignored.

In the seventies two researchers, Penzias and Wilson, using an antenna designed to capture centimetric radiation, discovered that, pointing it at any direction of the sky their antenna received such radiation. It was established that it corresponded to the farthest signal that could be received on Earth.

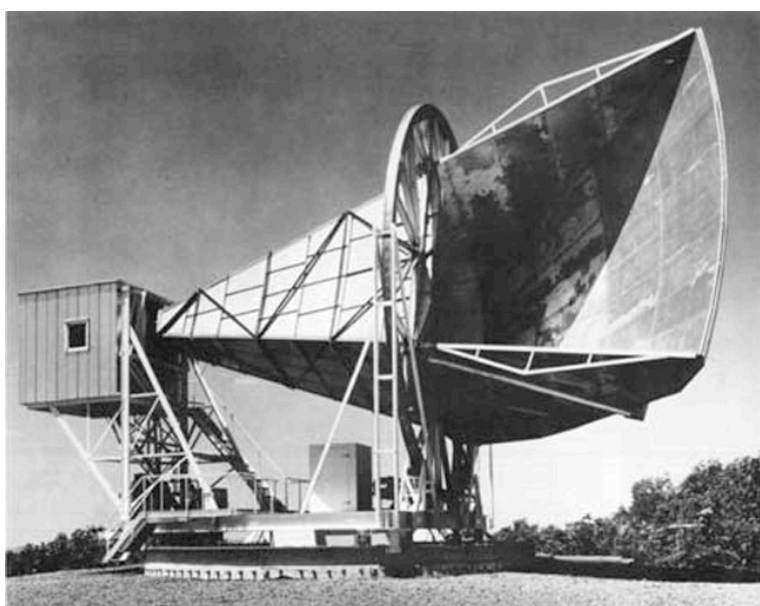

The antenna that first received CMB

When the universe is younger than 380,000 years, it is fully ionized, it's a plasma. Free electrons strongly react to electromagnetic radiation. For example, we know that it is impossible to communicate with an astronaut during the re-entry phase because the capsule is surrounded by a plasma.

During all his history the history of universe radiative process occurs. The average wavelength corresponds to the radiation temperature T_R . The higher the temperature, the smaller the wavelength. But this radiation is continuously absorbed and reemitted. As time flies the wavelength of the reemitted radiation grows. When the recombination occurs the emitted photons can cross space, because bounded electrons become insensitive to these tiny electromagnetic waves : the universe becomes transparent.

Why 3 degrees Kelvin :

The last emission corresponds to a plasma temperature $T_R = 3,000^\circ\text{K}$.

k being the Boltzmann constant, the energy of photons is

$$k T_R = h\nu = \frac{h c}{\lambda} \quad \rightarrow \quad \lambda = \frac{h c}{k T_R}$$

Introducing the numerical values we find $\lambda = 4.8 \text{ microns}$

When the universe expands the photon wavelength follows this expansion process.

If the age of the univers is 13 billions years this corresponds to a ratio

$$\frac{1.3 \cdot 10^{10}}{3.8 \cdot 10^5} = 3.4 \cdot 10^5$$

Assuming the expansion law is $R \propto t^{2/3}$

this corresponds to an enlargement ratio $\cong 1000$

which corresponds to the enlargement of the photon's wavelength, i.e. to the redshift z . So that , when captured, the wavelength corresponds to

$$\lambda' = 4.8 \text{ microns} \times 1000 = 4.8 \text{ millimeters}$$

which corresponds to a black body temperature

$$k T_R = h\nu = \frac{h c}{\lambda} \quad \rightarrow \quad T_R = \frac{h c}{k \lambda} \cong 3^\circ\text{K}$$

This is what appeared from the COBE data :

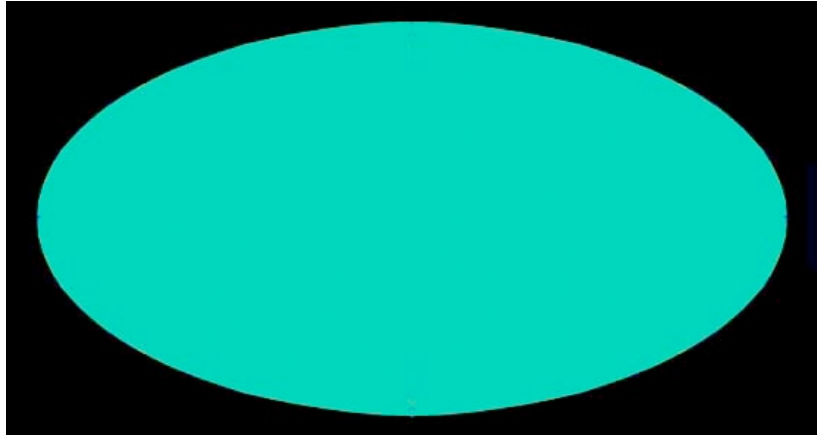

Fig.4 : The COBE data (non enhanced)

So, the cosmic background was found very homogeneous in any direction. This elliptic presentation corresponds to (transverse) Mercator mapping.

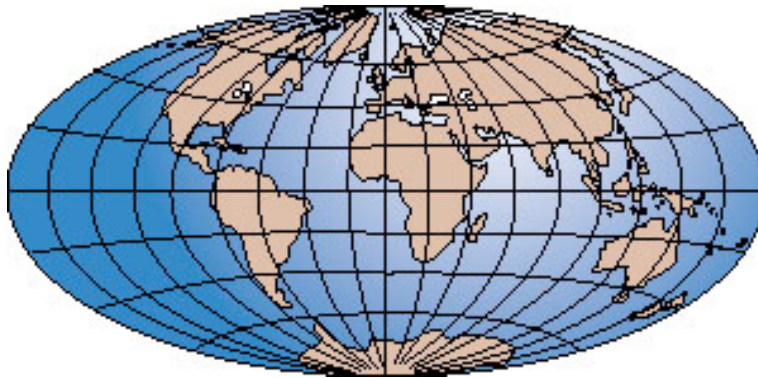

Fig.5 : Transverse Mercator mapping of the sphere

When enhanced by a factor 100,000 we get the wellknown image :

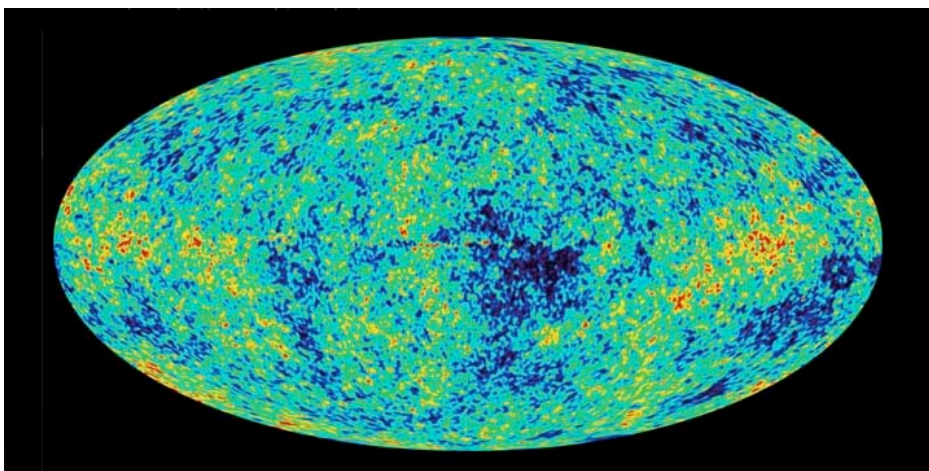

Fig.6 : Cosmic background. Enhanced data, factor 100,000

Homogeneity of the primeval universe

Back to figure 4 : How to justify such almost perfect homogeneity ?

Homogeneity needs an exchange process between distant portions of the universe. But the expansion process starts dramatically :

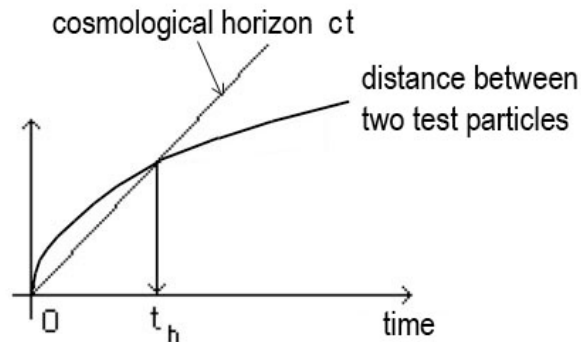

Fig.7 : Comparizon between horizon and distance between test particles

As we can see, at $t = 0$ two test particles move away, each from the other, at an infinite velocity. Then, as time flies, this expansion velocity decreases. But during a certain time the average distance between two neighbour particles is much larger that the radius ct of an electromagnetic wave emitted at $t = 0$ bu the particles. So, during than time they cannot communicate, be cause nothing can go faster that light.

Without interaction, any tiny unhomogeneity would be dramatically increased. As many people know this was solved by the so-called *inflation theory*. According to this model, at the very begining of the universe an incredible expansion would occurs at 10^{-36} sec and last to 10^{-33} sec/. The expansion rate would be 10^{26} . For details, see

[https://en.wikipedia.org/wiki/Inflation_\(cosmology\)](https://en.wikipedia.org/wiki/Inflation_(cosmology))

What produces this inflation process ? Answer : a mysterious particle called *inflaton*.

There are several justifications to the theory of inflation. According Grand Unification Theory the Big Bang should produce a lot of hypothetic heavy particles names magnetic monopoles. Though, as cosmologist Martin Rees writes : "Skeptics about exotic physics might not be hugely impressed by a theoretical argument to explain the absence of particles that are themselves only hypothetical. Preventive medicine can readily seem 100 percent effective against a disease that doesn't exist!"

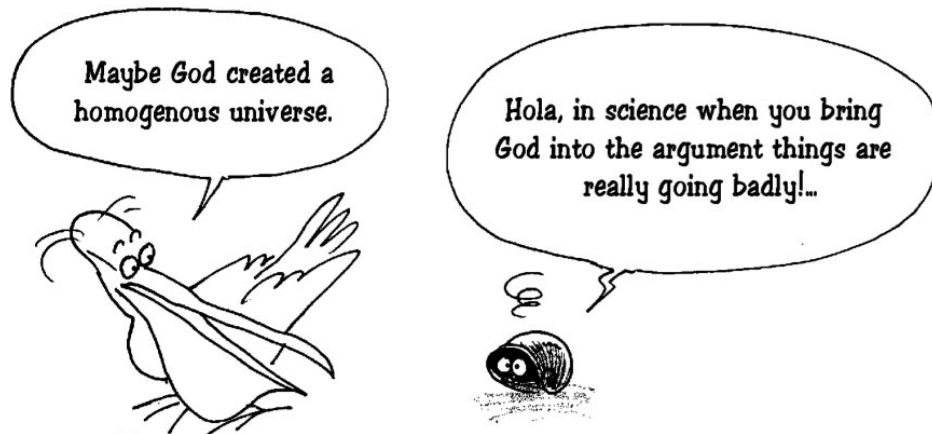

In 1988 I published a paper entitled :

Cosmological model with variable velocity of light

Later the scientists Moffat (1992) and Magueijo (1998) proposed their own versions.
See :

https://en.wikipedia.org/wiki/Variable_speed_of_light

But, as pointed out by researchers their approach modified Maxwell's equations so that a geometric property called « Lorentz invariance » was no longer preserved.

My model was different, because it was fundamentally based on the preservation of all equations of physics, including Maxwell.

In such equations a certain number of so-called constants appear :

c : speed of light

G : constant of gravity

h : Planck's constant

e : unit electric charge

M : mass

μ : magnetic permeability of vacuum

I added two « scale factors », one for space, a , and the other for time t and found in 1988 that there was only one universal gauge relationship that could link these eight quantities,

$$\{ c, G, h, e, m, \mu, a, t \}$$

while preserving all the equations of physics : Einstein's field equation, Schrödinger or Dirac equations, Maxwell equations, Boltzmann equation etc...

Physics behind the wall

What does it mean ?

As we said before, the early universe (for $t < 380,000$ yrs) remains a mystery, because we can't get information from the time before. All what we propose is speculative. In a word, the cosmic background is a wall we can't see through. How is the physics there ?

This gauge relationship answers the question : at this time our familiar equations of physics can be used (which is classically assumed). The universe experiences a generalized « gauge process ». The work was continued in 1995 [9] and in 2000 [10] . On next figure we see how the constants vary in time, during the radiation dominated era.

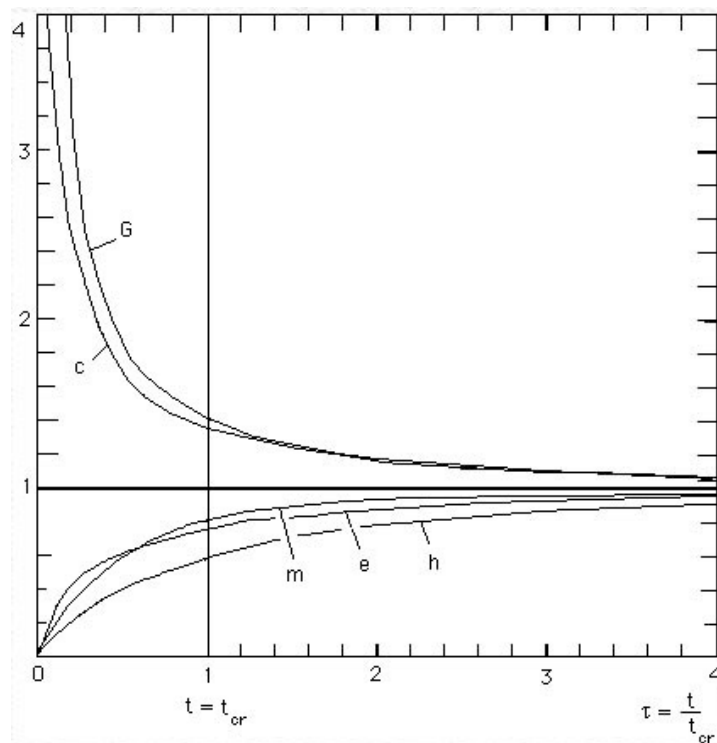

Fig.8 : Secular evolution of the constants of physics (reduced values).

As we can see, c and G tend to infinite when t tends to zero. Conversely the mass, the unit electric charge, the Planck's constant (I have forgotten the magnetic permeability of vacuum which experience similar variation) tend to zero.

When the density of energy of matter prevails (matter dominated era) these constants behave as ... absolute constants.

With respect to the other's model, mine preserves the fine structure constant α , which preserves atomic structure.

Today, science strongly depends on marketing activity. Authors have to be present in international conferences. It's better to form a group, a « pack ». Inside the group all guys quote the papers of the other members of the group, so that their scientific movement may grow like a french mayonnaise.

By the way, I don't know if I will be understood by american readers. For them, the mayonnaise is a sauce, a salad dressing that comes, ready for use, from a tube. Frenchies still make their mayonnaise by hand, from elementary components :

- egg yolk : one
- oil 25 cc
- mustard : one spoon
- salt, peper
- vineger (at the end)

Like in science, it requires to be strongly agitated to come up.

From that point of view I was at once out of the race. Alone, with no budget to take in charge missions. So that my work has been completely ignored since 28 years. Perhaps that will change if the Janus model has somme success someday, because it's an important part of this model.

Let's back to the paradox of homogeneity. According to this model the velocity of light is linked to the space scale factor a (the « size » of the universe) through :

$$c \propto \frac{1}{\sqrt{a}}$$

So, the cosmological horizon no longer varies linearly like t . Then the calculation shows that the cosmological horizon grows as the size a of the universe, so that its homogeneity is ensured at any time during the radiation dominated era.

$$\text{horizon} \propto a$$

Schematically :

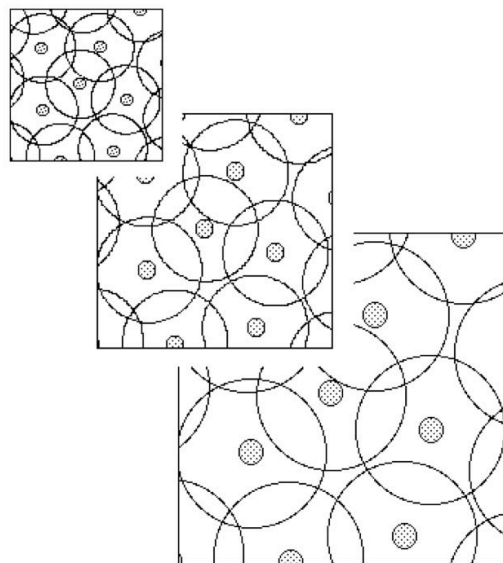
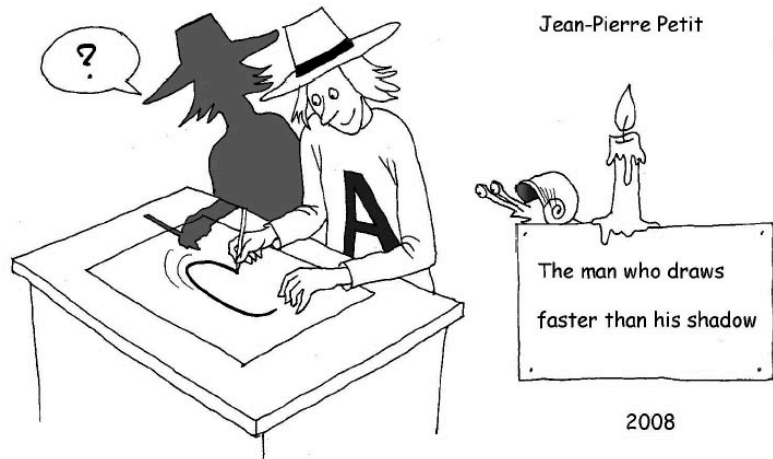

Fig.9 : Growth of the cosmological horizon in time

For more information go to my comic strip

FASTER THAN LIGHT

DOWNLOAD



http://www.savoir-sans-frontieres.com/JPP/telechargeables/English/faster_than_light/faster_than_light.pdf

A modern version of Zeno' paradox.

You perhaps know the famous [paradox of Zeno's of Elea](#) (ca. 490- 430 BC) called Achilles and the tortoise.

What is time ? An angle. An hour is figured by a turn of the long needle of your watch. A day is a turn of the Earth around itself. A year is a turn of the Earth, circling around the sun.

Imagine a conceptual clock made of two masses orbiting around their common center of gravity.

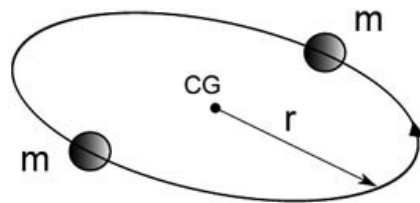

Fig.10 : An elementary clock

If we consider the period of rotation of such clock it involves the constant of gravity, the value of the mass and the orbitation radius. Taking account of the gauge process all these quantities vary. Then we can compute the number of turns from the origin of the universe to the present time.

We find an infinite number of turns

Sakharov said that the universe was like a book, opened at a page called « present ». The next pages represents the « future » and the precedent pages « the past ». Immediately we would like to flip back the book in order to reach the first page, on which the author has inscribed his foreword, showing his intentions.

But when flipping back the pages they begin thinner and thinner, at the end infinitely thin ! We never reach that foreword.

By the way, I have written another comic book about time, called

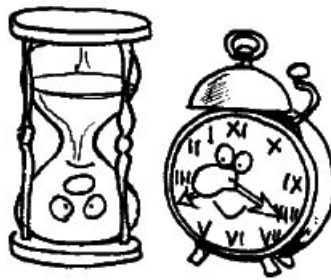

THE CHRONOLOGICON

http://www.savoir-sans-frontieres.com/JPP/telechargeables/English/chronologicon_eng/Chronologicon_anglais.pdf

What's « before » the Big Bang ?

Perhaps this question has no meaning. Think about Sakharov's model and his two enantiomorphic twin universes, created simultaneously, with opposite arrows of time. How could we figure that ?

Imagine a fully closed spacetime, figured as a 2-sphere. The Big Bang is at one pole and the Big Crunch at the opposite pole, located at its antipode. Space is one-dimensional, expanding, then collapsing, after a maximum expansion, figured by the equator of the sphere.

We know that we can identify antipodal points of a S^2 sphere which is transformed into a Boy's surface. See another Comic book :

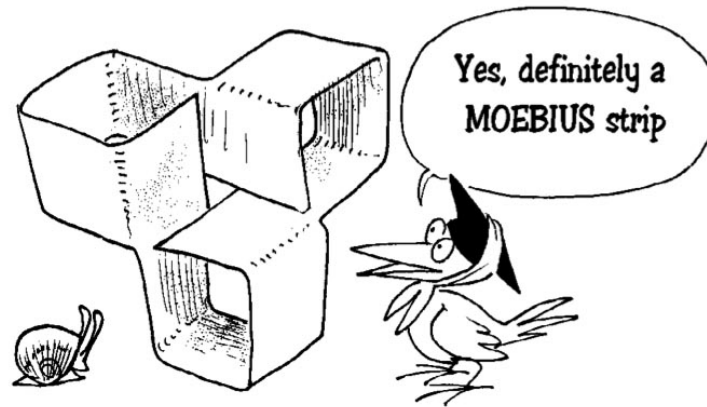

TOPO THE WORLD :

http://www.savoir-sans-frontieres.com/JPP/telechargeables/English/Topo_the_world_eng.pdf

Remember it is best to avoid reading this album :

- *In the evening before going to bed*
- *After a heavy meal*
- *Or were you're certain about nothing, because this will only make it worse*

Let's get back to our 2D space time :

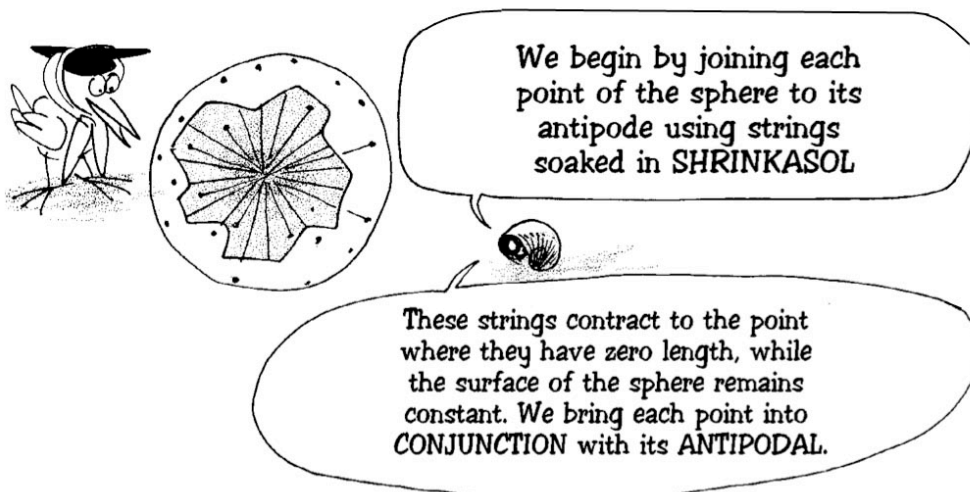

Next : the result :

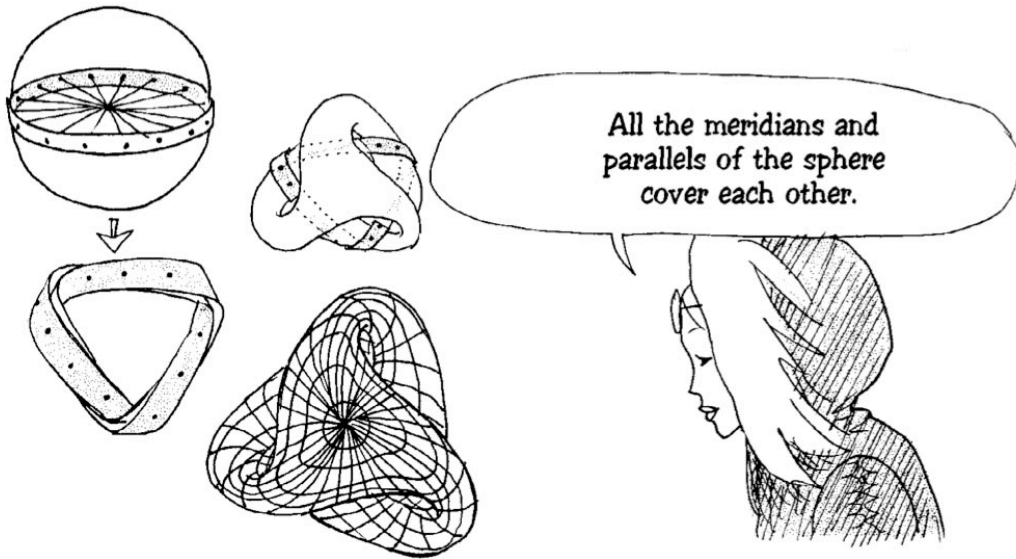

The result is a mapped Boy surface. The Big Bang and Big Crunch coincide at the single pole of the Boy surface. At any time two folds with opposite arrows of time coincide too :

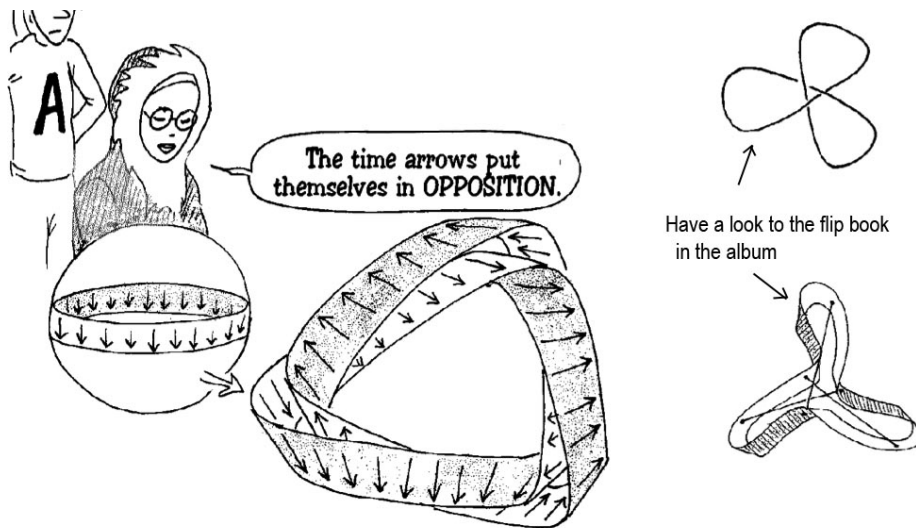

Notice you can shift to a three-dimensional Boy hypersurface. Then you can fold it by constant t surfaces :

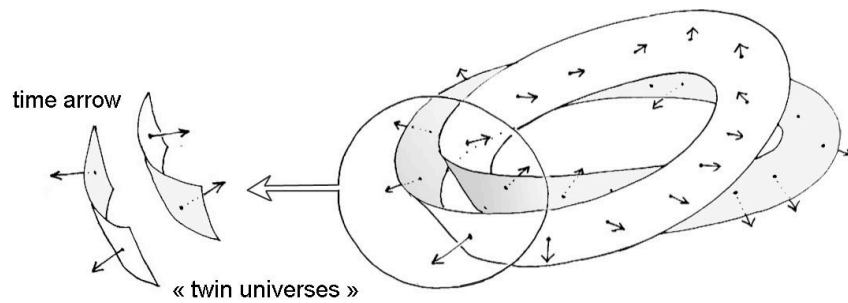

Fig.11 : Time-folding in a 3D Boy hypersurface

The so-called instant « $t = 0$ » would correspond to an achronic but highly chronogenic situation, followed by the immediate birth of two opposite arrows of time. The two « twin universe » correspond to fiber bundling. Notice they are enantiomorphic.

More precisely, the so-called « $t = 0$ » instant would correspond to achronic and *non-orientable* geometric structure. The cosmogenesis would correspond to a full symmetry breaking.

If we add electric charge, as will be shown further, a closed fifth dimension is required. Then we need to deal with a projective space P^5 (and probably P^{10} , if we add other quantum charges).

Eventually, if one wants to eliminate the Big Bang singularity it can be replaced by a space bridge and the multi-dimensional Boy Hyersurface Becomes a multi-dimensional Klein's bottle :

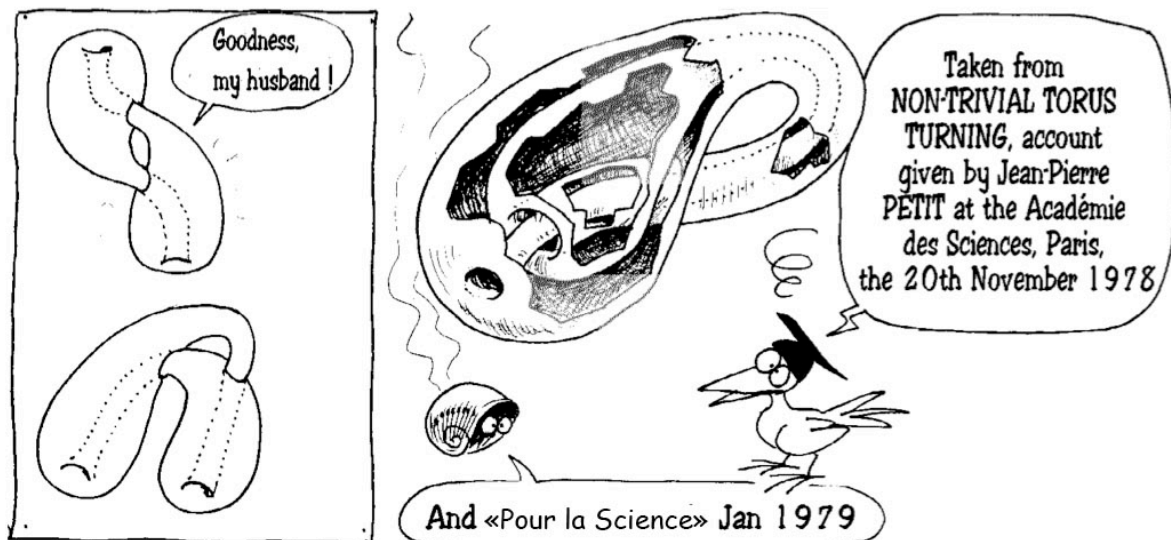

This non-trivial torus turning was a part of a paper issued in the french journal « Pour la Science », french edition of Scientific American. But, due to a lack of fair play, the US journal refused to publish this 13 pages french paper, devoted to the eversion of the 2-sphere.

The eversion of the 2-sphere (in french) :

http://www.savoir-sans-frontieres.com/JPP/telechargeables/Francais/retournement_sphere/PLS_79.pdfFig.12a

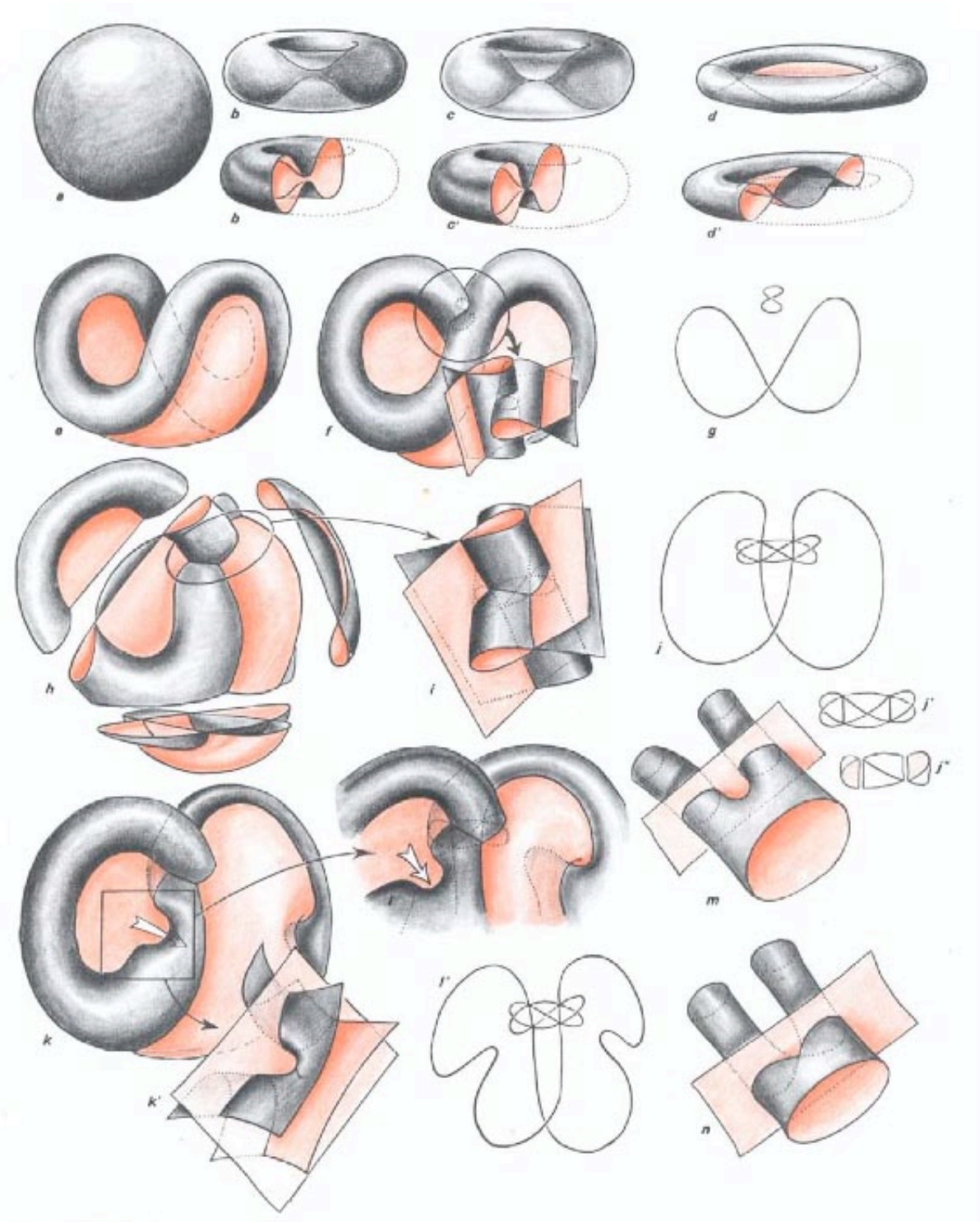

From the eversion of the 2-sphere, after Morin-Petit

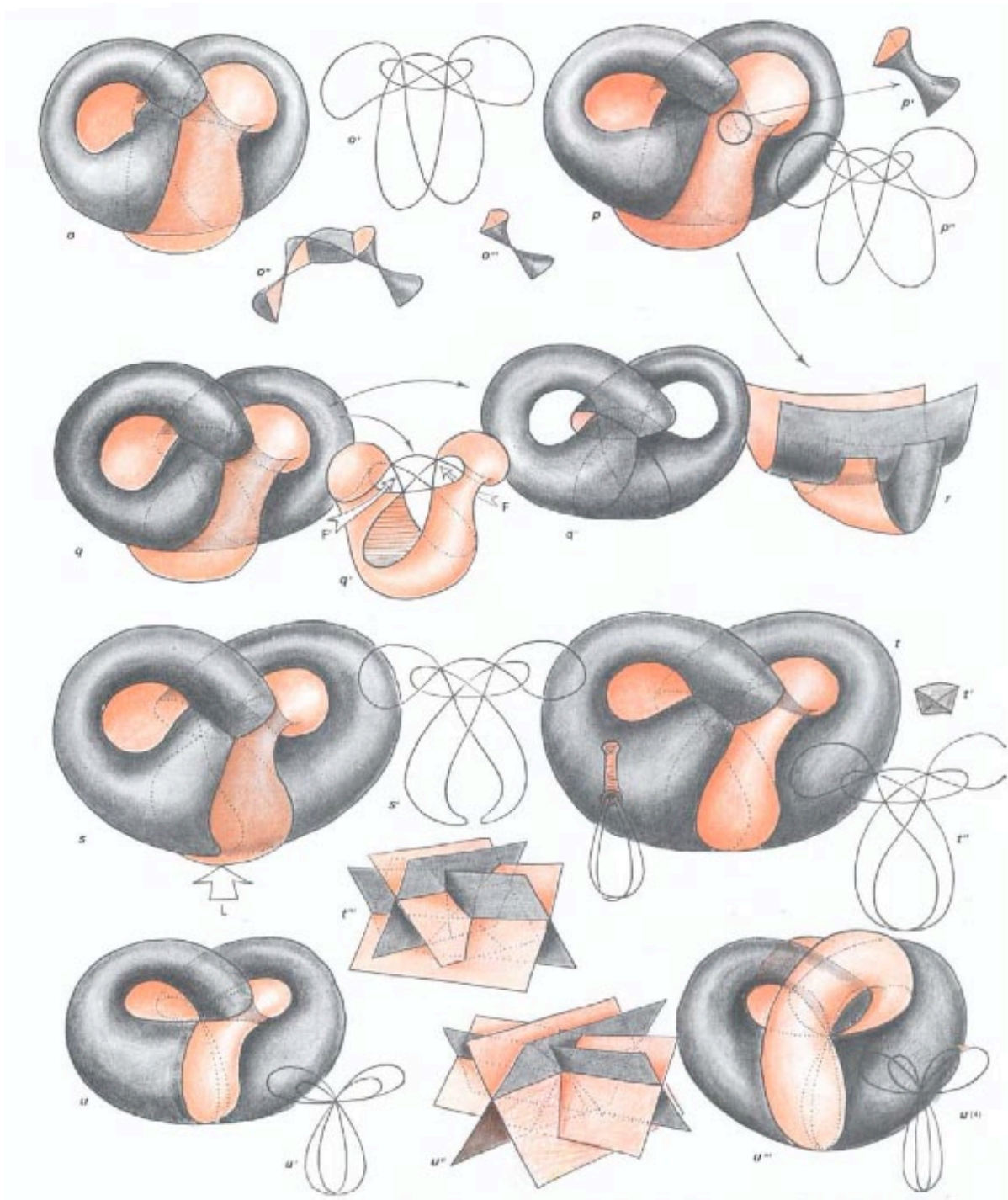

Fig.12b : From the eversion of the 2-sphere, after Morin-Petit

Next : the polyedric version of the central model (part of the eversion of the 2-cube)

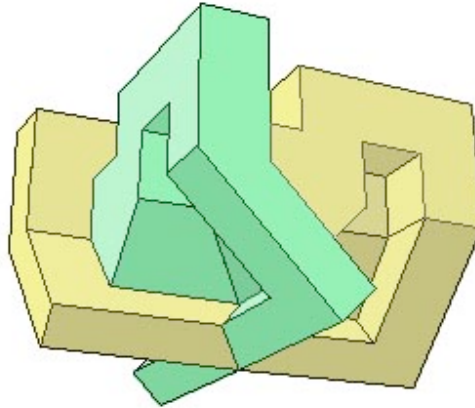

Fig.13 : The central model of the eversion of the 2-cube.

Getting more in relativistic world

Such material formed the geometric support of my first paper about *relativistic twin universe theory*, issued in the journal *Nuovo Cimento* in 1994 [7], after thirty unsuccessful attempts and classical rejection answer :

- *Sorry, we don't publish speculative works*

In this paper I developed the intuition that « twin matters » had opposite sign masses, with the following conjectural laws of interaction :

- *matter attracts matter through Newton's law*
- *« twin matter » attracts « twin matter » through Newton's law*
- *matter and « twin matter » mutually repel through « Anti-Newton's law ».*

This introduced the first description of the universe as a M4 manifold plus two metrics $g_{\mu\nu}^{(+)}$ and $g_{\mu\nu}^{(-)}$, solutions of a coupled field equations system.

In the present paper I try to be understood by the largest public as possible. So I have to give some insight on General Relativity.

To become more familiar to Special Relativity , perhaps first see



EVERYTHING IS RELATIVE :

http://www.savoir-sans-frontieres.com/JPP/telechargeables/English/EVERYTHING_IS_RELATIVE.pdf

Then, for initiation to curved space, see



HERE IS LOOKING AT EUCLID

http://www.savoir-sans-frontieres.com/JPP/telechargeables/English/HERE_S_LOOKING_AT_EUCLID.pdf

This book was printed in the US. The editor, afraid of the possible negative reactions from American public morality leagues, decided to dress the heroin in a more decent way. Following, the initial uncensored French version of that page.



uncensored version :

<http://www.savoir-sans-frontieres.com/JPP/telechargeables/Francais/LE%20GEOMETRICON.pdf>

More in :

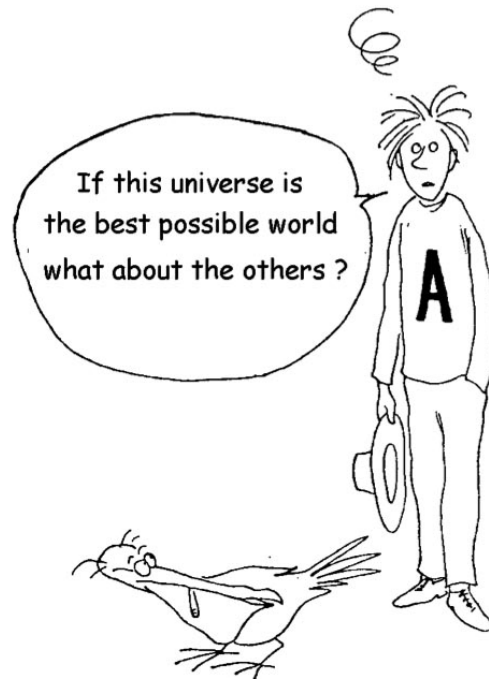

Black hole, american version :

http://www.savoir-sans-frontieres.com/JPP/telechargeables/English/THE_BLACK_HOLE.pdf

uncensored version :

http://www.savoir-sans-frontieres.com/JPP/telechargeables/Francais/LE_TROU_NOIR.pdf

As you may discover in those albums the general issue of General Relativity is to change a description corresponding to an Euclidean universe where points-masses are subjected to forces into a new model in which the paths of particles, or planets, correspond to geodesics of some curved 4D hypersurface.

The set of geodesics is computed from a metric, which is a function of the space-time coordinates (t, x, y, z)

In general this is limited to two extreme situations

- In steady state solutions the $g_{\mu\nu}$ are functions of (x, y, z)
- In time dependent solutions $g_{\mu\nu}$ are functions of the time coordinated t

The mathematical objet $g_{\mu\nu}$ is a « tensor », but you can, roughly talking, consider it as a matrix (four lines, four colums) so that it contains 16 terms. But this is strongly reduced by considerations of symmetry. In general the final calculation refers to only two différential equations.

We are not going to enter in the details of the calculation. In general, considerations of symmetry makes cosmologists to choose some peculiar form of the matrix $g_{\mu\nu}$. It makes possible to compute another mathematical object, called the « Ricci tensor » (another matrix). Another operation gives a scalar called « the Ricci scalar ». Then one introduces these elements in the Einstein field equations (a « matrix » equation), which rapidly reduces to two differential equations :

How to build a solution of Einstein's equation :

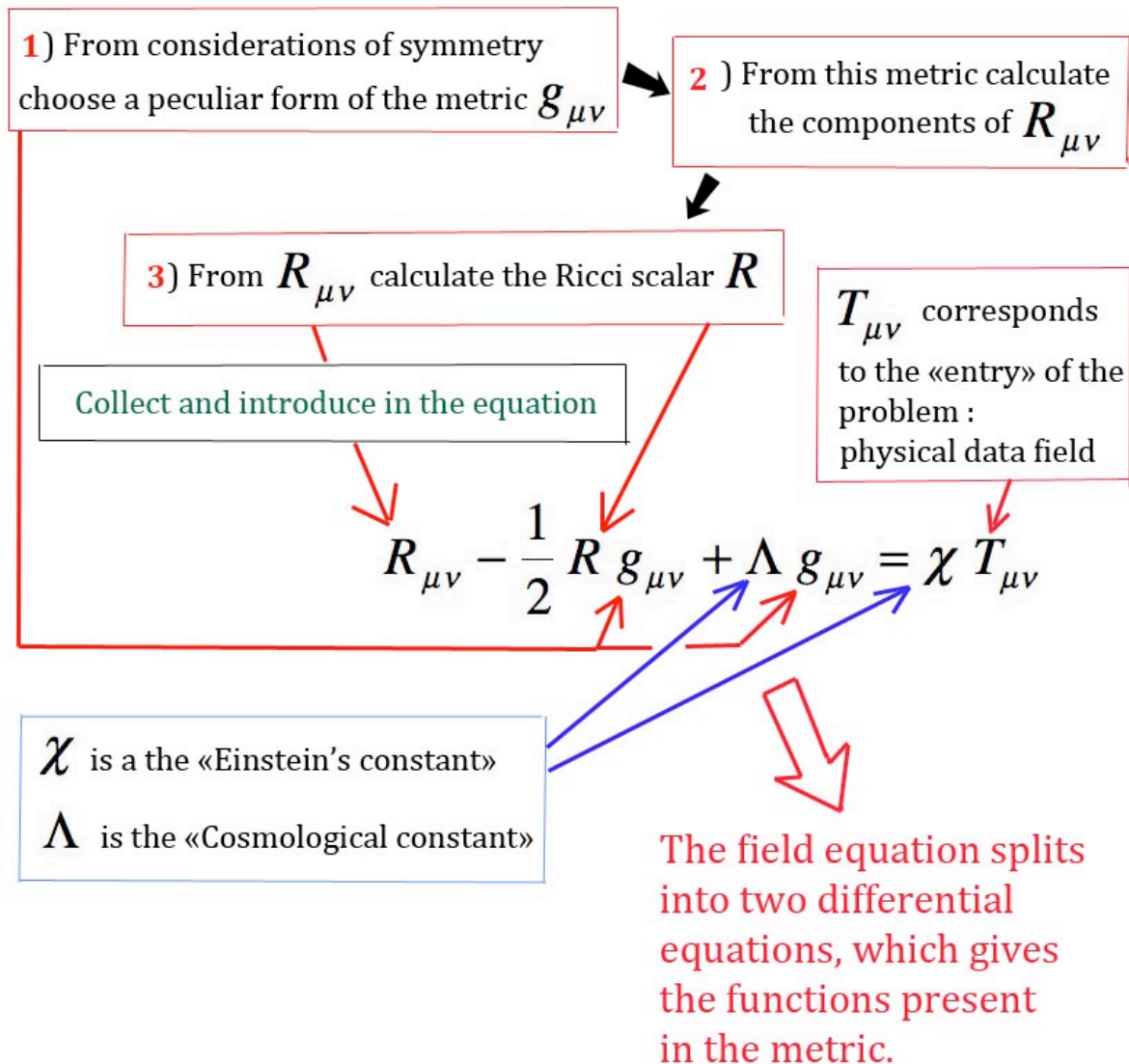

Why nobody tried to introduce negative mass during 57 years

The astrophysicists know that peculiar time-independant solution, discovered by the German Karl Schwarzschild in 1916 provides almost conical paths of planets, considered as mass-points, orbiting around the sun.



Karl Schwarzschild 1873-1916

Schwarzschild was a brilliant mathematician and astronomer. In 1916, aged 42 years, married and father of a little girl, he enlists German army to fight Russian during the first world war. There, he discovers the field equation, proposed by Einstein in the proceedings of the Prussian Academy of Science. He rapidly finds two fundamental exact solutions of this equation, immediately published in this journal, but dies few months after from an autoimmune disease.

The geodesic paths from Schwarzschild's solution are very close to the plane Newtonian paths (elliptical, hyperbolic or parabolic). Similarly when applying « Newtonian approximation » to the Einstein's field equation this gives the interaction force, the Newtonian force.

- (positive) masses m and m' mutually attract through a force $\frac{G m m'}{d^2}$

Newtonian approximation : one considers a portion of space with weak curvature and velocities small with respect to the speed of the light.

G being the constant of gravity and d the distance between the two masses.

What happens if one introduces negative masses ?

It has been investigated by Herman Bondi in 1957.



Herman Bondi 1919 - 2005

Then the Newtonian approximation provides the following interaction laws :

- *positive mass attracts positive mass through Newton*
- *positive mass attracts negative mass through Newton*
- *negative mass repels negative mass through anti-Newton*
- *negative mass repels positive mass through anti-Newton*

In few words :

Positive masses attract everything

Negative masses repel everything

It produces the so-called *Runaway Paradox*

Consider two masses with opposite signs

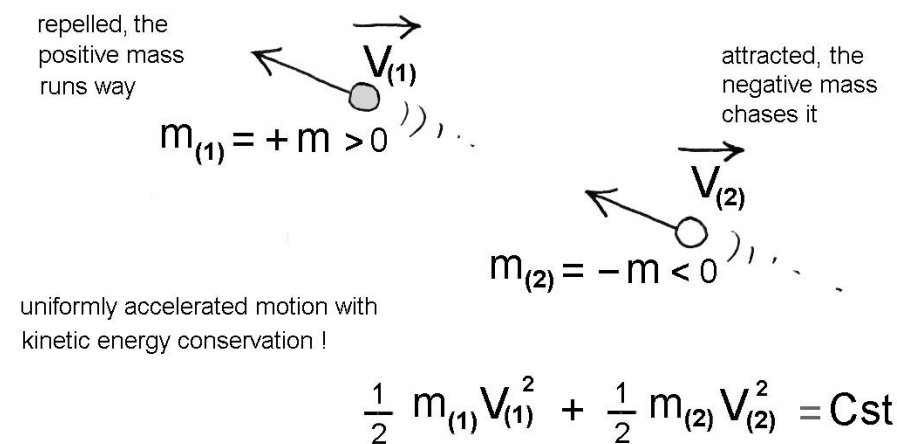
RUNAWAY PHENOMENON :Fig. 14 : the *unmanageable* Runaway phenomenon

This prevented any attempt to build a cosmological model with positive and negative masses, during 57 years. Until ...

How to avoid the runaway phenomenon

In 1994 I presented the first *bimetric*² model [7] , where

- $g_{\mu\nu}^{(+)}$ metric, which refers to positive mass
- $g_{\mu\nu}^{(-)}$ metric, which refers to negative mass

This was a complete change of geometric paradigm

In spite of new publications in high level peer reviewed journals in 2014-2015 this work receives absolutely no echo. Recently I installed a paper in Researchgate website showing how the so-called « central singularity » of the Schwarzschild solution (which becomes, by the way, « the central singularity » which stands « at the center of black holes ») can be cancelled by a simple coordinated change.

This paper broke the records of downloadings.

So what ?

- *Where are the comments from black hole men ? No comments.*
- *How the scientific journalists comment our works ? They don't.*
- *Where are the echos in the Internet ? Nowhere.*

² Which has nothing to do with other bimetric model in which the second metric refers to massive gravitons.

Eight years ago (!...) I have written a new album, presenting the Janus Cosmological Model.

http://www.savoir-sans-frontieres.com/JPP/telechargeables/English/gemellaire_anglais/twin_universe.pdf

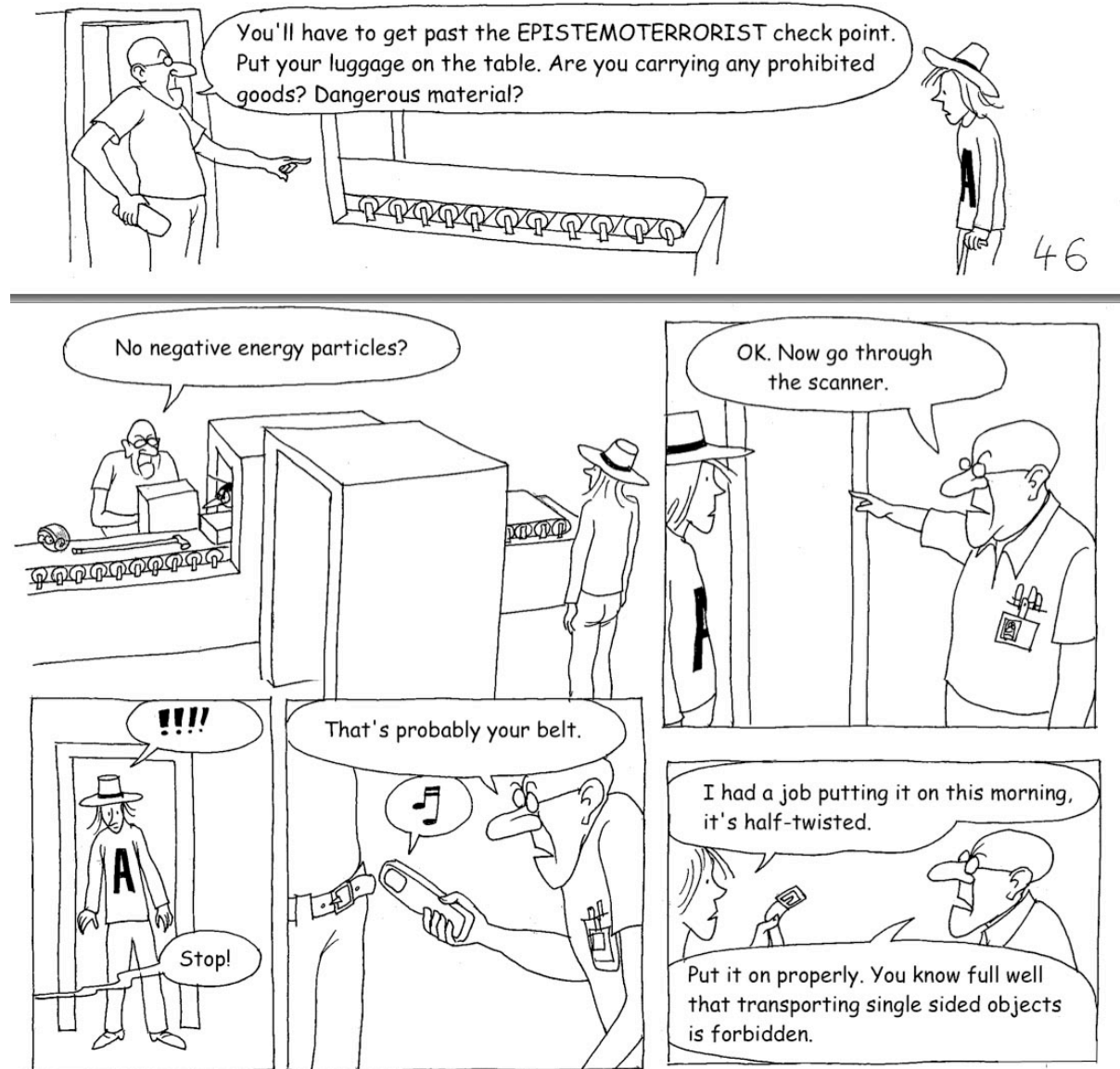

Echo ? Messages from colleagues ?

None

If you are not specialist in differential geometry, cosmology, please look first at this album.

Our work is a call for a full change of paradigm. It attacks the « dark science », in which our science is going down with all hands. But the project is dangerous for a lot of researchers.

In 1917, when Albert Einstein introduced General Relativity it did not demolish the classical physics but extended it. Astronomers could continue to use the good

Newtonian tools. General Relativity just installed weak phenomena, like the advance of the periphery of Mercury.

When the phenomenon was discovered the French astronomer Le Verrier, who discovered the Neptune planet by calculations, suggested that the anomaly could be due to a planet named Vulcania, whose orbit would be located between the one of Mercury and the sun ;

Today, if General Relativity was not invented someone would suggest it is simply a « dark planet », that we cannot observe.

Janus' revolution is completely different. It attacks dark matter and shows that was a complete mistake. The negative mass is not « a new kind of dark matter ». It implies a completely different vision of the universe.

If we win, what about the other's works ?

A pure catastrophe.

It makes me think about a painting of the French painter [Lecomte du Nouÿ](#), entitled :



The men who bring bad news :

Indeed, the Janus model is a very bad new for cosmic men and black hole men. Too much things should be abandoned. How to imagine that people would accept to extend General relativity to a Janus model based on two coupled field equations !?!

$$R_{\mu\nu}^{(+)} - \frac{1}{2} R^{(+)} R_{\mu\nu}^{(+)} = \chi \left[T_{\mu\nu}^{(+)} + \sqrt{\frac{g^{(-)}}{g^{(+)}}} T_{\mu\nu}^{(-)} \right]$$

$$R_{\mu\nu}^{(-)} - \frac{1}{2} R^{(-)} R_{\mu\nu}^{(-)} = -\chi \left[\sqrt{\frac{g^{(+)}}{g^{(-)}}} T_{\mu\nu}^{(+)} + T_{\mu\nu}^{(-)} \right]$$

Is it the end of Einstein's work ? No, it extends it.

Positive and negative matter mutually repel, so that the content of negative mass in the solar system is almost zero.

$T_{\mu\nu}^{(-)}$ is a tensor that shows the local content of negative « energy-matter ». So that, in the solar system, where positive matter prevails, it tends to zero, and the system becomes :

$$R_{\mu\nu}^{(+)} - \frac{1}{2} R^{(+)} R_{\mu\nu}^{(+)} \simeq \chi T_{\mu\nu}^{(+)}$$

$$R_{\mu\nu}^{(-)} - \frac{1}{2} R^{(-)} R_{\mu\nu}^{(-)} \simeq -\chi \sqrt{\frac{g^{(+)}}{g^{(-)}}} T_{\mu\nu}^{(+)}$$

The first equation is nothing but Einstein's equation, which becomes the approximate version of Janus model when negative material can be neglected.

How to sell that !?!

The geometric context

In 1905 Albert Einstein introduced the Special Relativity, which was described as a new vision of the universe, horribly difficult to understand.

In effect, it's a main change of geometric vision which can be summarized by a unique sentence :

- *We live in a Minkowski space*

You don't need anything more. All the Special Relativity's features are contained in this short sentence.

But Minkowski space is highly puzzling.

In an Euclidean space the Pythagore theorem holds. In two dimensions :

- *The square of the hypotenuse of a right-angled triangle is the sum of the squares of the two other sides.*

It can be extended to three dimensions.

- *The square of the main diagonal of a right-angled parallelogram is the sum of the squares of its three sides.*

Consider an Euclidean 3D-space, with coordinates $\{ x, y, z \}$ and a small displacement $\{ dx, dy, dz \}$. The square of the length of the vector displacement $d\vec{s}$ is :

$$ds^2 = dx^2 + dy^2 + dz^2$$

It corresponds to the *metric* of that Euclidean 3D-space

The Minkowski space introduces the concept of space-time, with four coordinates $\{ t, x, y, z \}$. Consider the following 2D space time : $\{ t, x \}$ and a displacement $\{ dt, dx \}$ in that space.



Hermann Mikowski 1864-1909

Died suddently of appendicitis at 44 years

Minkowski says :

$$ds^2 = c^2 dt^2 - dx^2$$

- Gosh ! The square of the hypotenuse is equal to the *difference* of the square of the two other sides. How can I put that in my brain ?

No human creature can do that. You can't do it *and I can't do it too*. We are not hard-wired for such purpose. It's the beginning of a puzzling conclusion : Our brain is not equipped to face physical reality. Same conclusion for Quantum Mechanics.

The Janus model introduces a new geometric feature :

- *Between two distinct points there are two different distances.*

Simple : it depends what metric you use to measure length.

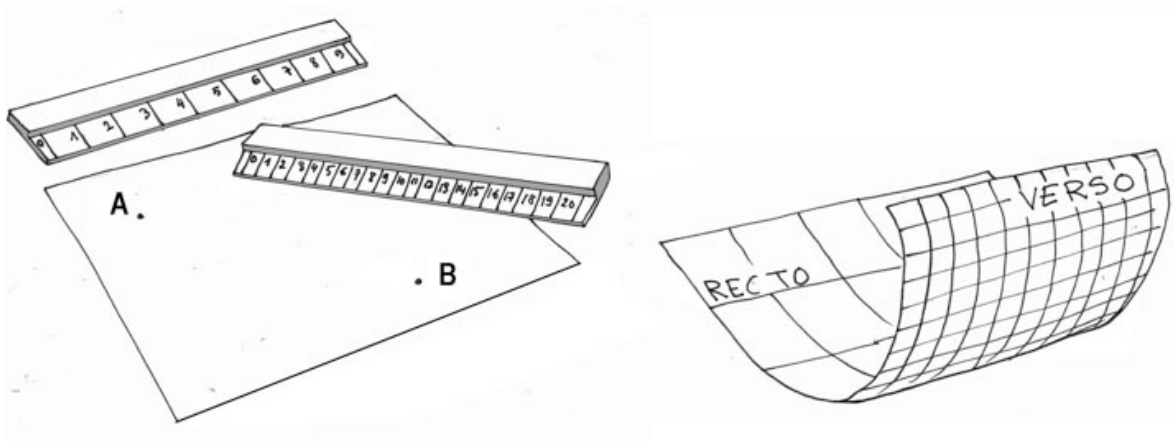

A 2D surface with two different scales

In physics one uses to introduce an « observer ». In Janus model what the universe shows to you depends on the matter you are made of, positive or negative. It can be observed by two distinct observers and the appearance is different for the two. It explains the chosen name Janus Univers.



A pioneer in Mathematical Physics is the french mathematician Jean-Marie Souriau.

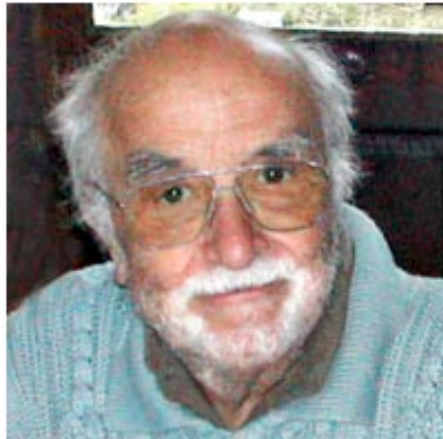

[J.M.Souriau](#) 1922-2012³

³ In his book « structure of dynamical systems », Birkhauser Ed he shows (for specialists, chapter III, page 190, equation 14.67) that time-inversion goes with energy and mass inversion.

Negative masses are invisible to us

We are made of positive mass. So our eyes and telescope capture positive energy photons. As negative masses emit negative energy photons we cannot capture any negative light emitted by such negative masses. They are fully *invisible*.

Observation brings information from the « positive world ». We can just guess how the things are going on in the « negative world ».

Where is this « negative world », where are the negative masses ? Among us. In the same space. As they are repelled by positive masses they are confined in the space which is between the galaxies and fill the big voids of the (lacunar) [large structure of the universe](#).

In the solar system the very small density of negative matter could produce weak phenomena like the braking of the Pioneer X probe.

With the progress of astronomy, observers measured the distance to galaxies with more and more precision. They rapidly discovered that galaxies gathered , forming clusters. Before 1989 one considered that galaxy clusters were the largest structures. But in 1989 astronomers discovered the Great Wall, a set of galaxies (matter) 500 x 200 light-years large, only 15 light-years width. Then they discovered what they called The Great Void, 130 light-years large. Following, the observational result :

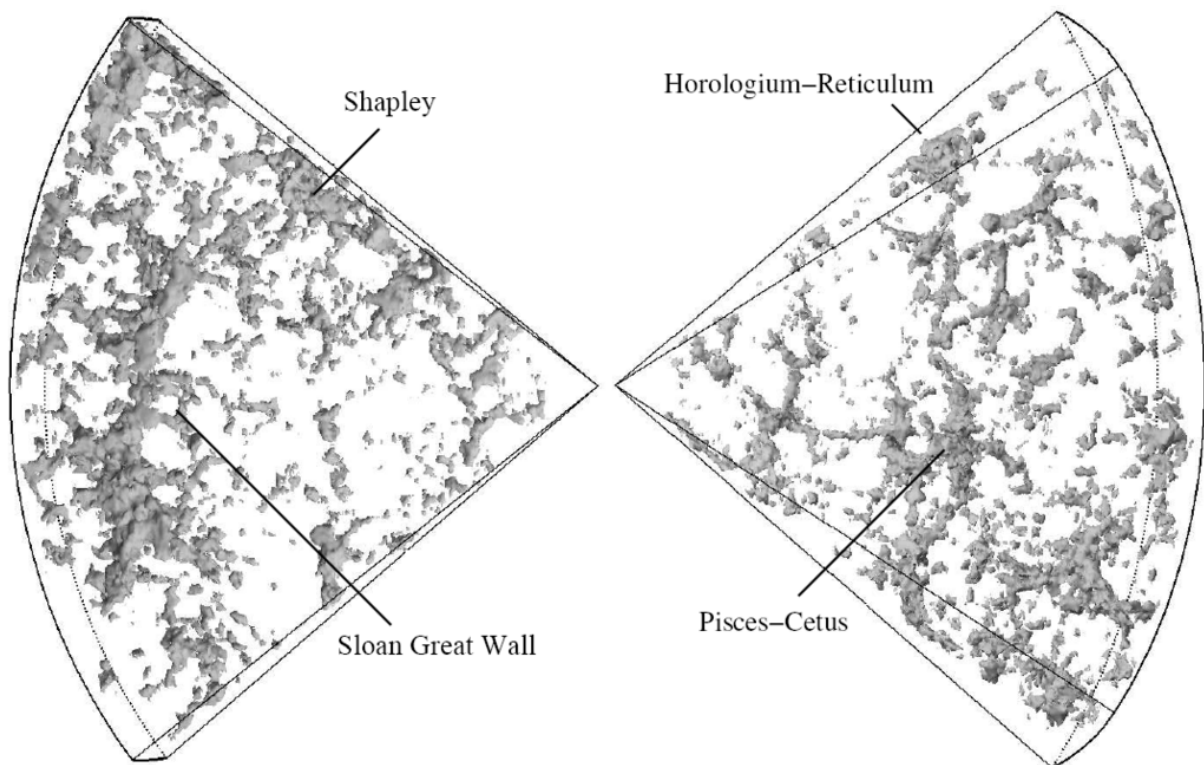

Fig.15 : The typical large structure of the universe. Two « slices »

Personally I think the universe looks like joint soap bubbles :

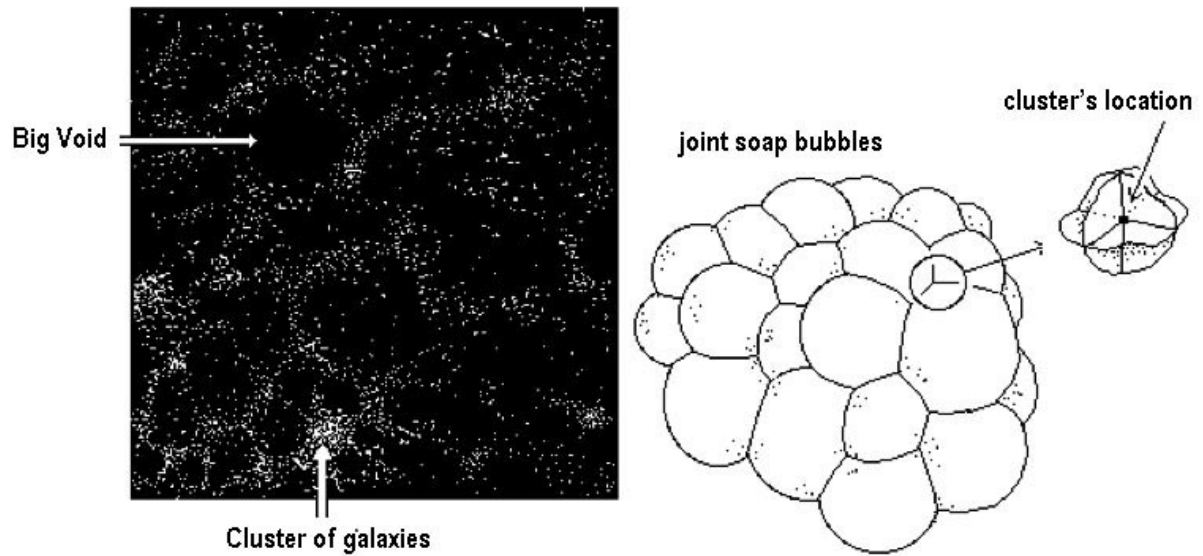

Fig.16 : Joint soap bubbles's like structure

Astrophysicists do not explain why such voids form.

First 2D simulations

Janus model does it. In 1991, through numerical 2D-simulations we studied, my old friend Pierre Midy and I, on a Cray-one, a set of 500 mass-points, positive and negative, with same density and averaged random velocities. As a result we got that :

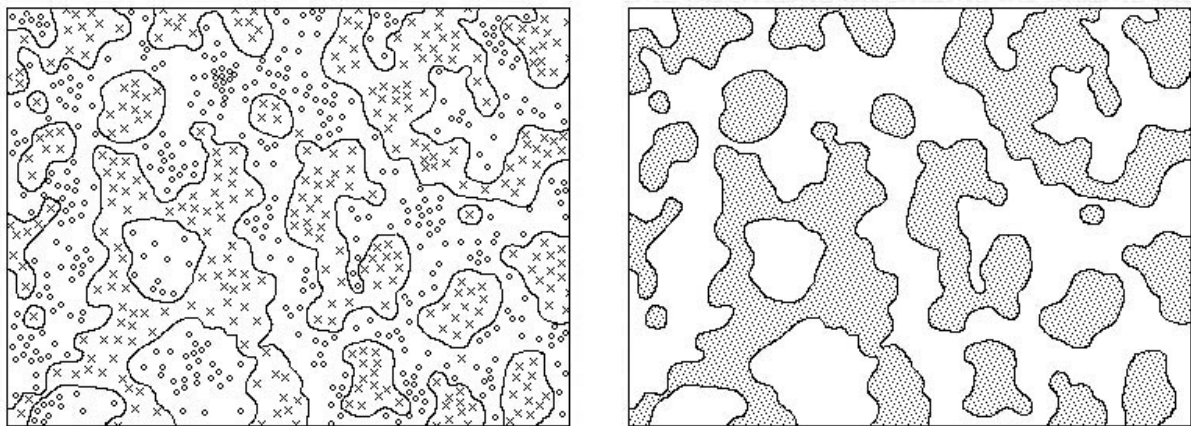

Fig.17 : Percolation phenomenon

But it did not resembled the large scale universe.

In 1992 a young student, Frédéric Dascamp, working at the DAISY center, Germany, visited me. I remember he said :

- *What could you do with your old Mac Intosh personal computer? At DAISY we have a big one. Describe a problem, I think I could manage it.*

I suggested to introduce a difference of the densities of the two species, taking the negative one larger. I knew that the accretion time⁴ was shorter, for a species with higher density. Frédéric went back to Hamburg and phoned me, few days later.

- *Well, what is the result ?*
- *I would say : « call me God ! »*

As I guessed negative mass formed clusters and repelled matter in the remnant place, this last forming a lacunar structure (that was published 3 years later in *Astrophysics and Space Science* [9], after 30 new unsuccessful trials).

Since 1992 we have never had the opportunity to extend that to 3D-simulations, in a bigger system. In 2000 I attended an international meeting in Marseille [10], France, 20 kilometers from my home. The subject of this meeting was « where is the matter ». You must understand « where is the dark matter ? ». Nobody cared with negative matter.

I showed a picture of my 2D lacunar structure. Reaction of the audience :

None

Then I made 70 copies of a 70 pages report about my work, carried this material the day after with two heavy suitcases with wheels and installed, before the first session, a copy in front of each participant. At the end of the report I mentioned my coordinates, phone number, and said I would be opened to any collaboration.

I did not find any of my 70 report in the wastebaskets, but nobody contacted me. I still was the «neutrino », a nickname that my friend Guy Monnet gave me in the seventies. Or perhaps people considered me as some sort or extraterrestrial.

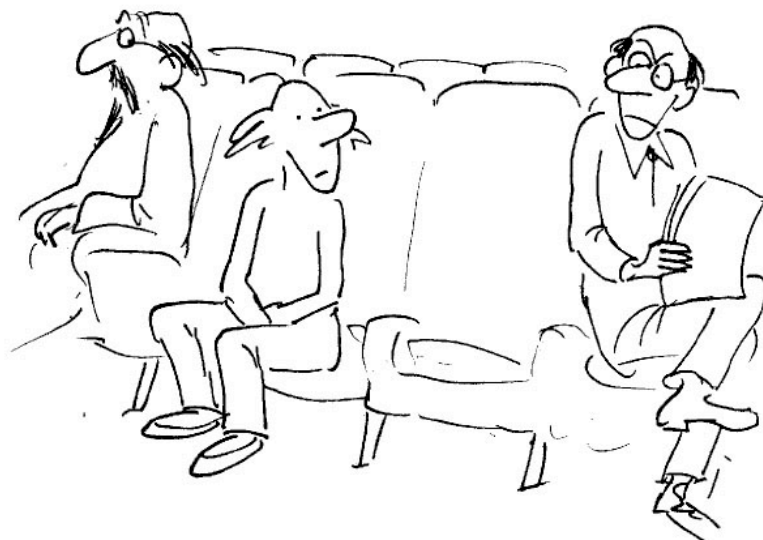

⁴ The Jeans time

At this meeting people watched the first mapping of dark matter, based on weak lensing effect.

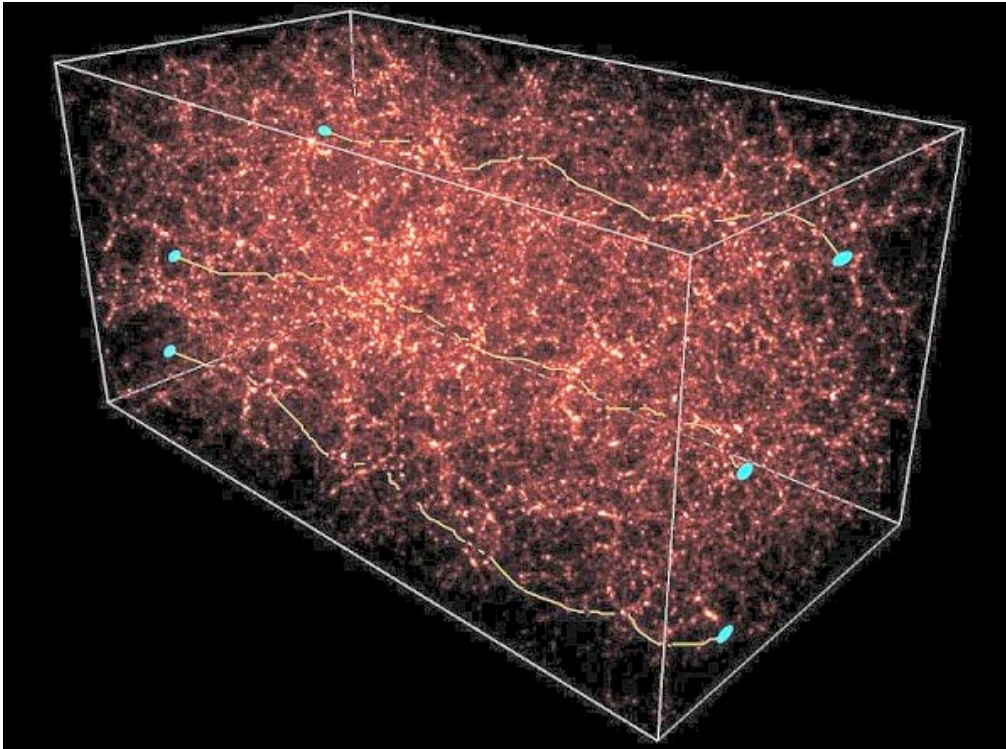

Fig.18 : Dark matter mapping

I have to admit that their colour images were much more beautiful than my black and white pictures.

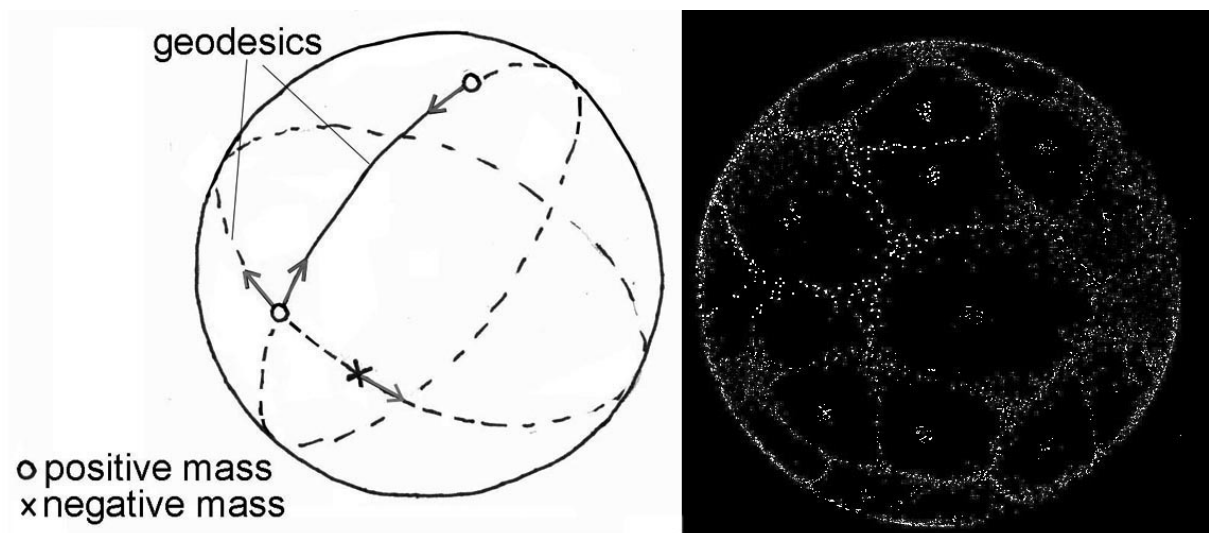

Fig.19 : 2D VLS simulation on a closed space. Newton's law based on geodesic distance

Science in clandestinity

Back to 1992. Frederic said :

- *It's amazing. Do you have another problem ?*

From an exact solution of a 2D Vlasov equation I had computed a nice spheroidal galaxy, surrounded by negative material.

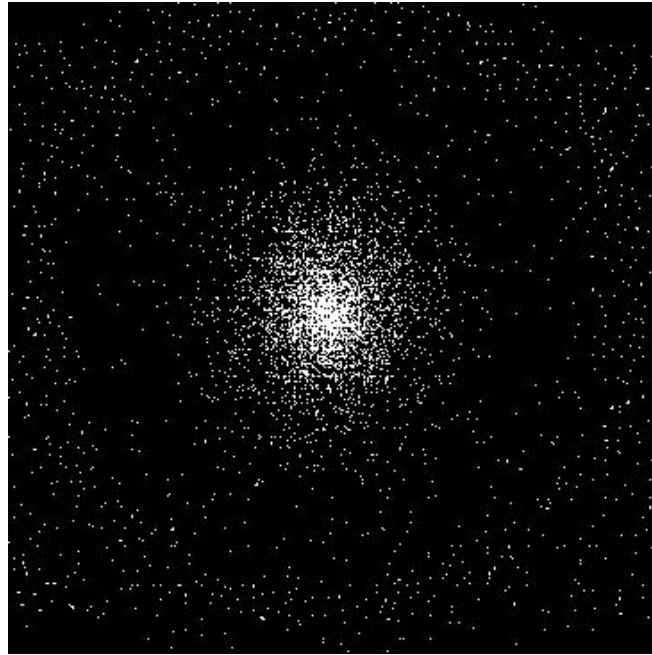

Fig.20 : 2D rotating « galaxy » surrounded by negative matter

Freredic put that in his big computer and produced a film showing the quick birth of a barred galaxy, which continued, without losing its spiral arms, during tens of turns. It was amazing, because other's numerical galaxies lost their arms after a single turn, due to the increase of velocity of their mass points. In our simulation, the surrounding negative mass acted like a potential barrier.

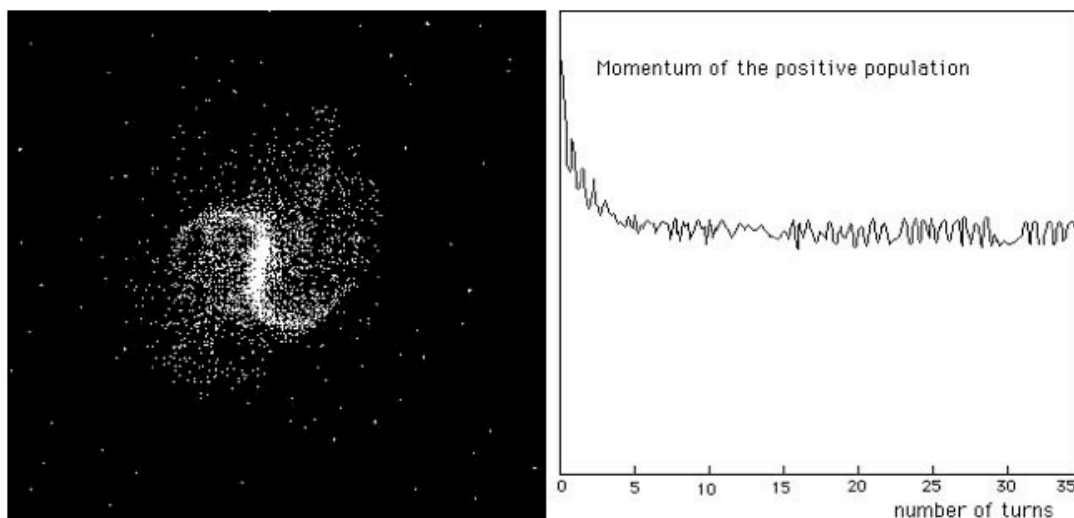
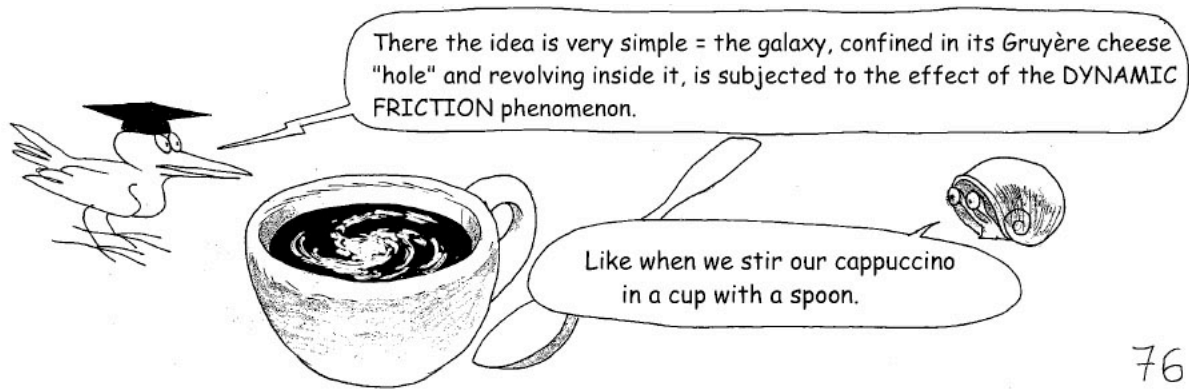

Fig.21 : 1990 ; my nice numerical 2D barred spiral

On the right I plot the rotational momentum. It shows that the galaxy is strongly slowed down during the spiral structure formation. Then the slowing down because insensitive. As you can see, a good image of a spiral galaxy is nothing but the rotating coffee with cream in a coffee cup.



76

I suggested to Frederic to weak the density of the negative mass. Immediately such corset could no longer play its role. The galaxy exploded and we got all kinds of « irregular galaxies ». Conversely if that density was strenghtened, we got that :

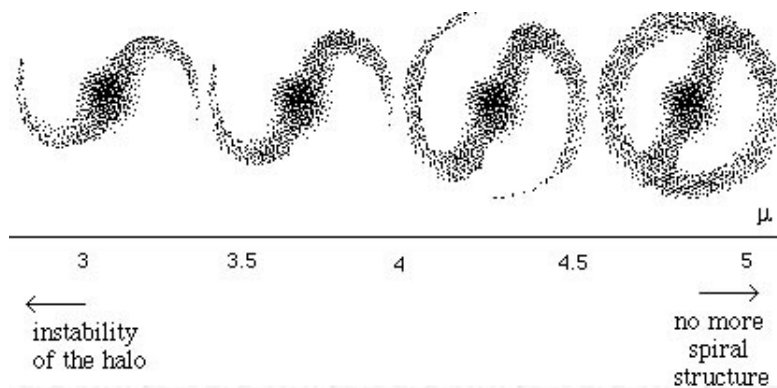

Fig.22 : From barred spiral to car's wheel galaxy



Fig.23 : The galaxy NGC 1010

But suddenly Frederic called me :

- *My boss has discovered that I used the computer of the center for a job that has nothing to do with the accelerator of particles. He said the lab cannot stand such clandestine activity, that must be stopped immediately. I'm sorry, but I can't continue.*

That was, after three months, the end of the story, 28 years ago.

I tried during years to publish a paper in astrophysical journals but I received ten times the copy and paste classical answer :

- *Sorry, we don't publish speculative works*

Discouraged I shifted to other subjects, paper and pen works.

About the formation of galaxies

The work of Frederic strengthened my personal vision of the birth of galaxies that I presented in *Nuovo Cimento* two years after, in 1994. According to this schema the lacunar structure forms rapidly, immediately after the end of the radiation era. Clumps of negative mass form, repel and compress positive matter along flat plates. This compression heats this matter, but the geometrical layout is optimum for the dissipation of the energy by radiation emission.

This outsider schema should deserve a fantastic campaign through 3D simulations, in front of a complete lack of idea

Is life present in the negative world ?

Clumps of negative mass are spheroidal. We can compare it to huge protostars.

When a star forms it starts from the condensation of a gaseous mass. Protostars are spheroidal objects at 2000° . Gravitational energy is converted into thermal energy. To become a real star, with fusion in its core, the protostar must shrink. But pressure force opposes the process. The amount of energy to be dissipated grows like the radius of the star, while the surface of the radiator grows like the square. So the bigger the star the longer its cooling time.

The clusters of negative matter are so big that their cooling time exceeds the age of the universe. If a traveller could use the « negative world » to achieve interstellar travels, thanks to a « mass inversion system », he would see masses emitting weakly reddish light (and infrared radiation).

These clusters do not contain atoms heavier than negative mass hydrogen, and negative mass helium. They do not create any galaxy, any star, any planet. So that life is absent, there.

What could reveal the presence of such clusters ?

Positive energy photons, emitted by distant galaxies, do not interfere with negative mass clusters by electromagnetic force, so they can cross it completely. This induces negative gravitational lensing effect, firstly described in 1995 [9].

We recall what is the gravitational lensing effect, first evidenced by Eddington in 1918. In General Relativity masses follow geodesic lines. But photons paths are also modified by such curvature concentration. All that was described by Karl Schwarzschild in his paper of 1916.

We can figure the path of positive energy photons as the geodesics drawn on a smoothed « posicone ».

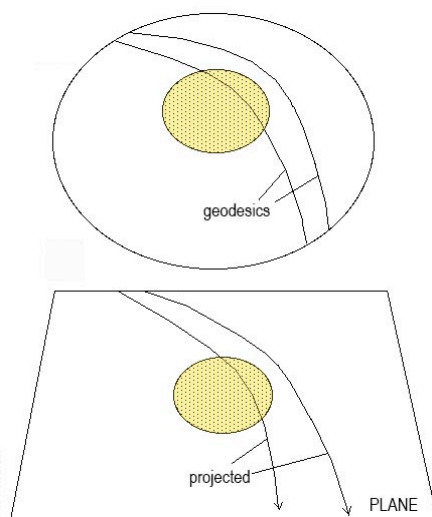
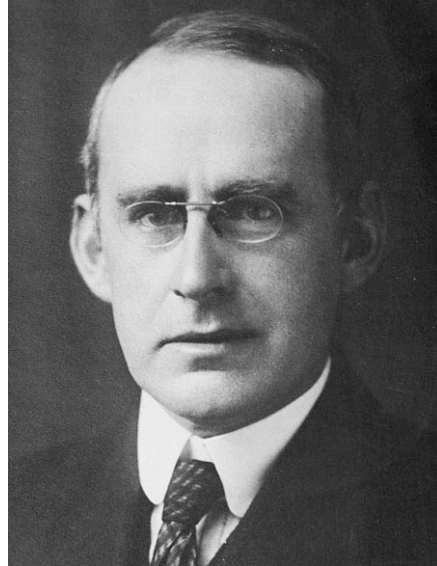

Fig.24 : The geodesics on a smoothed cone and their projection on a plane

This is similar in 3D. After the emergence of the solution of this General Relativity field equation Artur Eddington, very enthusiastic, organized an expedition in the gulf of Guinea in order to check the theory.



A.S.Eddington 1882-1942 (died aged 61)

At this time a total eclipse occurred in this region, so that they could observe the apparent movement of distant stars as they passed behind the sun. Pictures were taken, which confirmed Einstein and Schwarzschild calculation (remember Schwarzschild died few months after his discovery).



A.Einstein in 1919 . (1879-1955)

Masses behave like convergent lens.

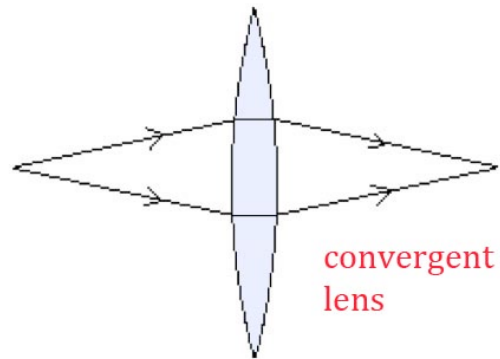

Fig.25 : A convergent lens concentrates the light rays

If the effect is strong, due to huge concentrations of mass (galaxy clusters) this can transform the image of a distant galaxy, located in the background as a gravitational mirage. The space telescope Hubble has captured impressive corresponding images :

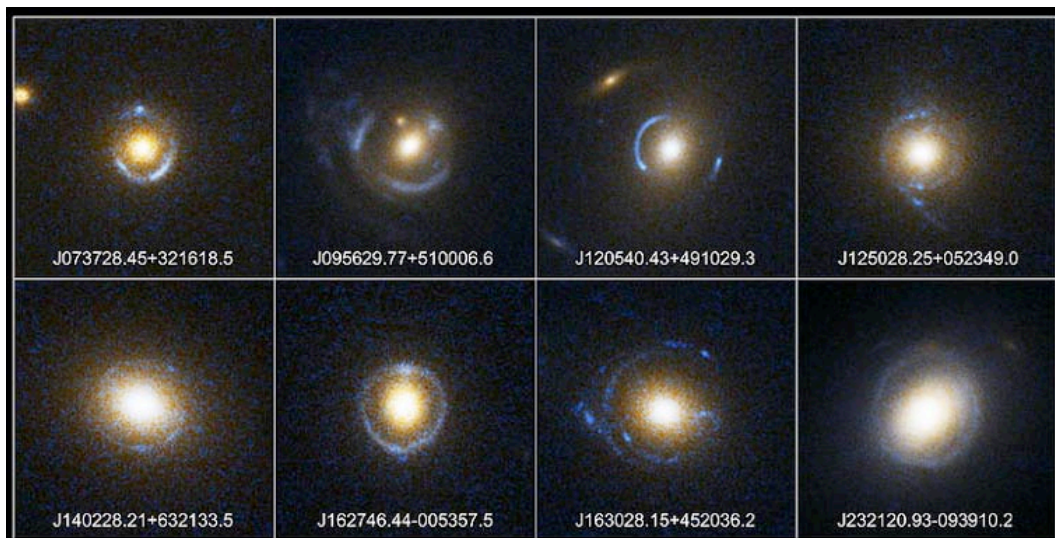

Fig.26 : Einstein Ring Gravitational Lenses

But negative a negative mass acts on the positive energy light like a divergent lens.

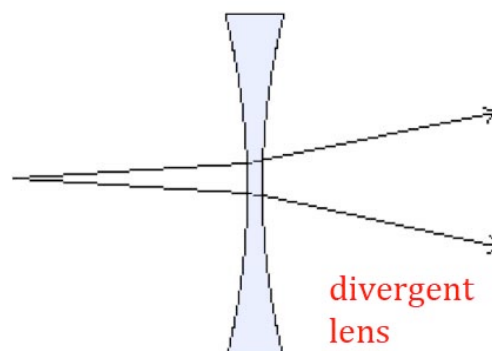

Fig.26 : A divergent lens spreads the rays

A divergent lens reduces the amount of energy captured and the apparent magnitude of the source.

Similarly a negative cluster reduces the magnitude of distant sources (young galaxies) by weak lensing effect. This light can cross the object.

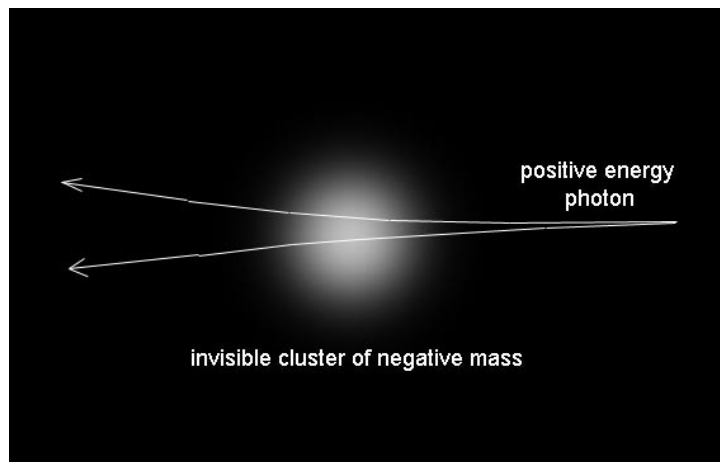
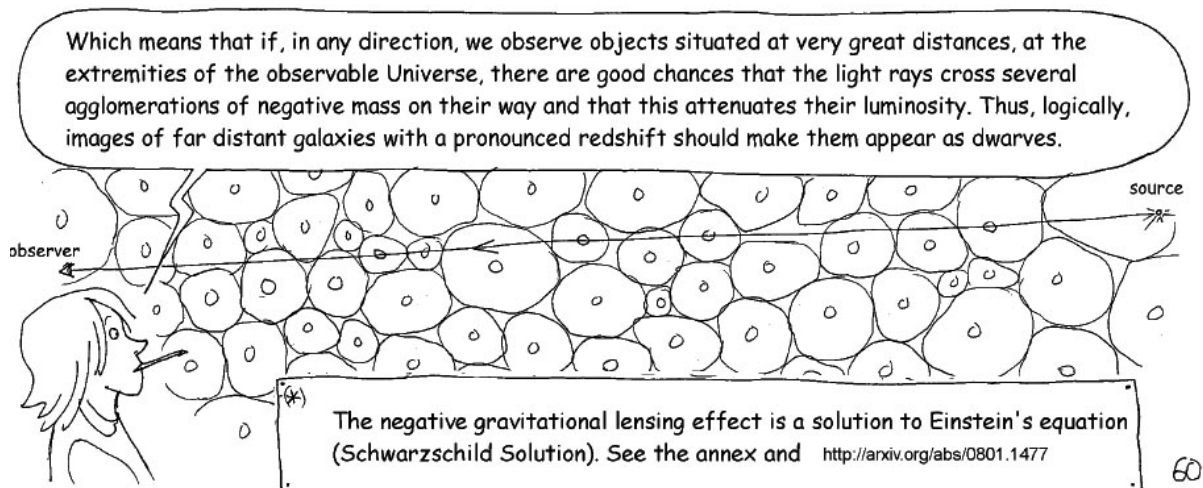

Fig.27 : Reduction of the magnitude of distant galaxies, du to negativ e lensing

The reduction of magnitude effect could provide an information about the siez of the clusters



In effect, distant galaxies are classically considered as dwarves. But it could be the proof that negative mass cluster reduce the magnitude of « normal » galaxies, du to negatice lensing effect.

An alternative mapping the the invisible components of the universe.

Since the en of the eighthies researchers started to map the universe, focussing on (positive) weak lensing effect. Imagine you observe a picture made of circular spots, disc, on a black background, through two lens, a convergent and a divergent. You will get that :

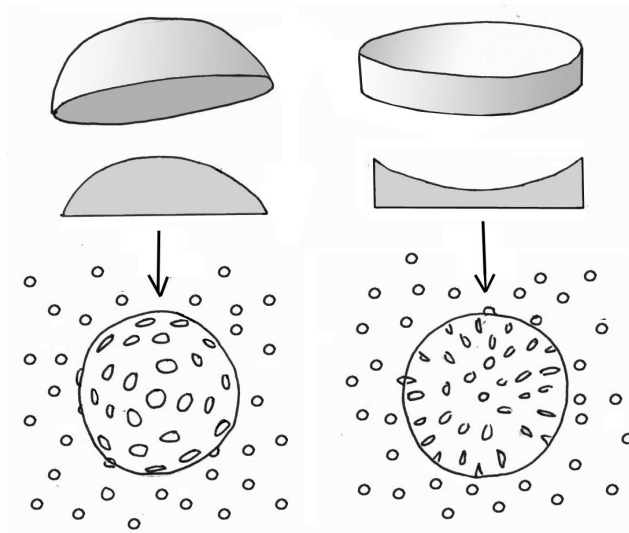

Fig.28 : Optical distortions due to onvergent and divergent lenses

Carefull analysis of available data, *based on positive weak lensing effect*, with powerfull computer has provided a 3D mapping of so-called dark matter. Hereafter a 3D map built from the Hubble telescope COSMOS survey :

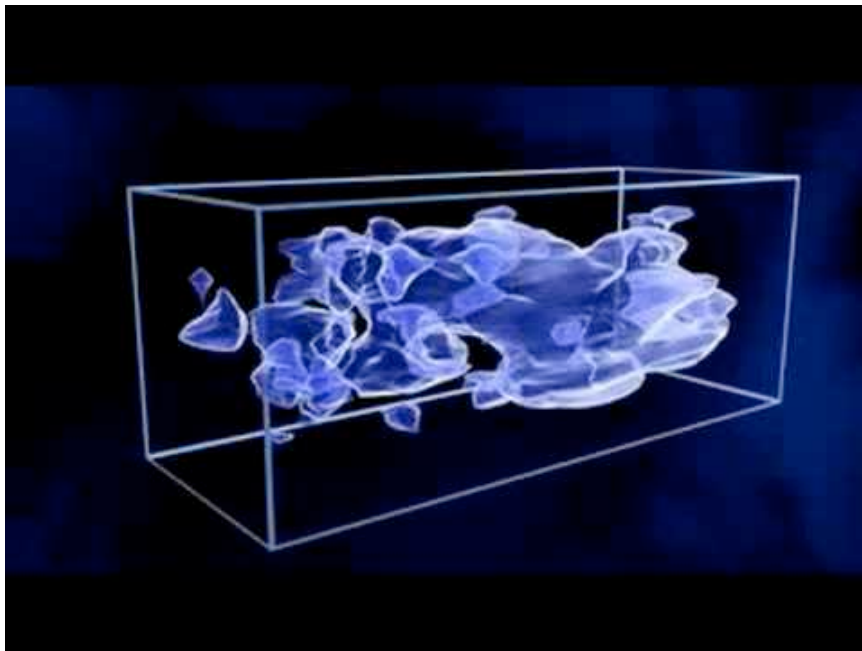

Fig.29 : 3D Dark matter map from Hubble COSMO survey data

On the net you can find a lot of beautiful images, like this one, more precise. But, warning ! They come from ... simulations.

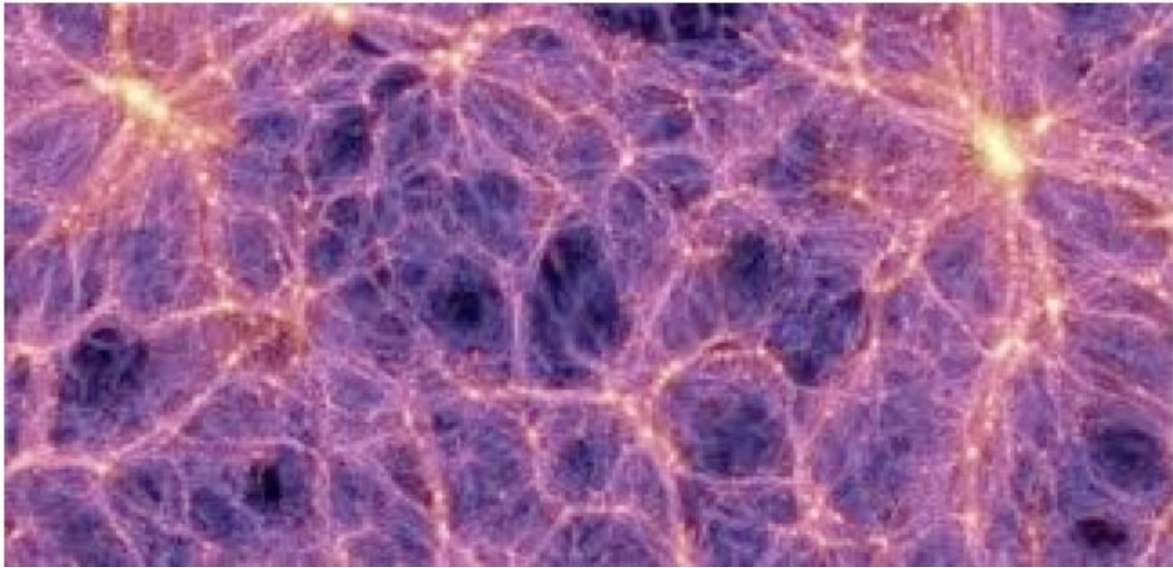
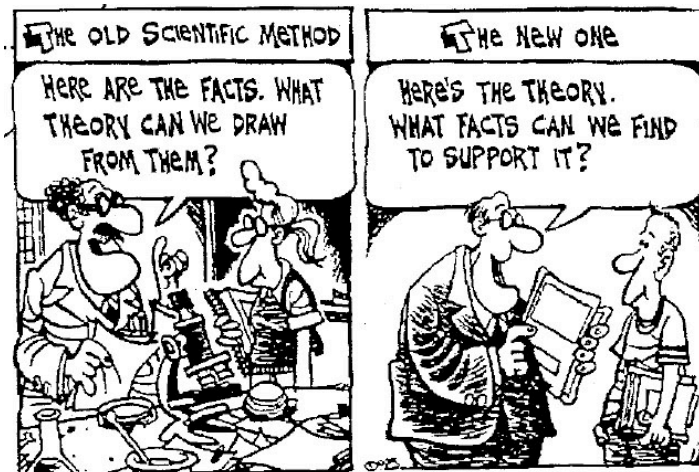
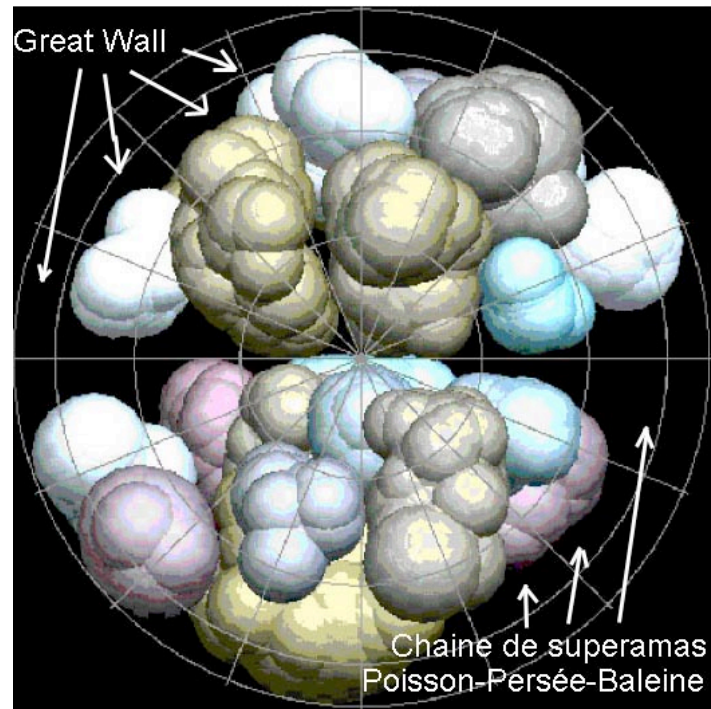

Fig.30 : 3D Dark matter map (simulation)

It's beautiful : it must be true !



If we assume that the distortions come from *negative* weak lensing phenomenon then we get a different method to decode the available avobservational data. This has been suggested by a Japanese team in 2013 [11]. Perhaps somebody will carry on this job. It would be interesting to see if he would refind the general mapping of the bid voids, designed as joint bubbles, as derived by the Israelian Tsvi Piràn, from observational data [12] :



Explaining the acceleration of the expansion.

The accelerated expansion was discovered in 1998, when two independent projects, the Supernova Cosmology Project and the High-Z Supernova Search Team simultaneously obtained results suggesting an acceleration in the expansion of the universe by using distant type Ia supernovae as standard candles. The discovery was unexpected, cosmologists at the time expecting a deceleration in the expansion of the universe, and amounts to the realization that the universe is currently in a "dark-energy-dominated era".

We are still in the « dark science », with ad hoc explanations.

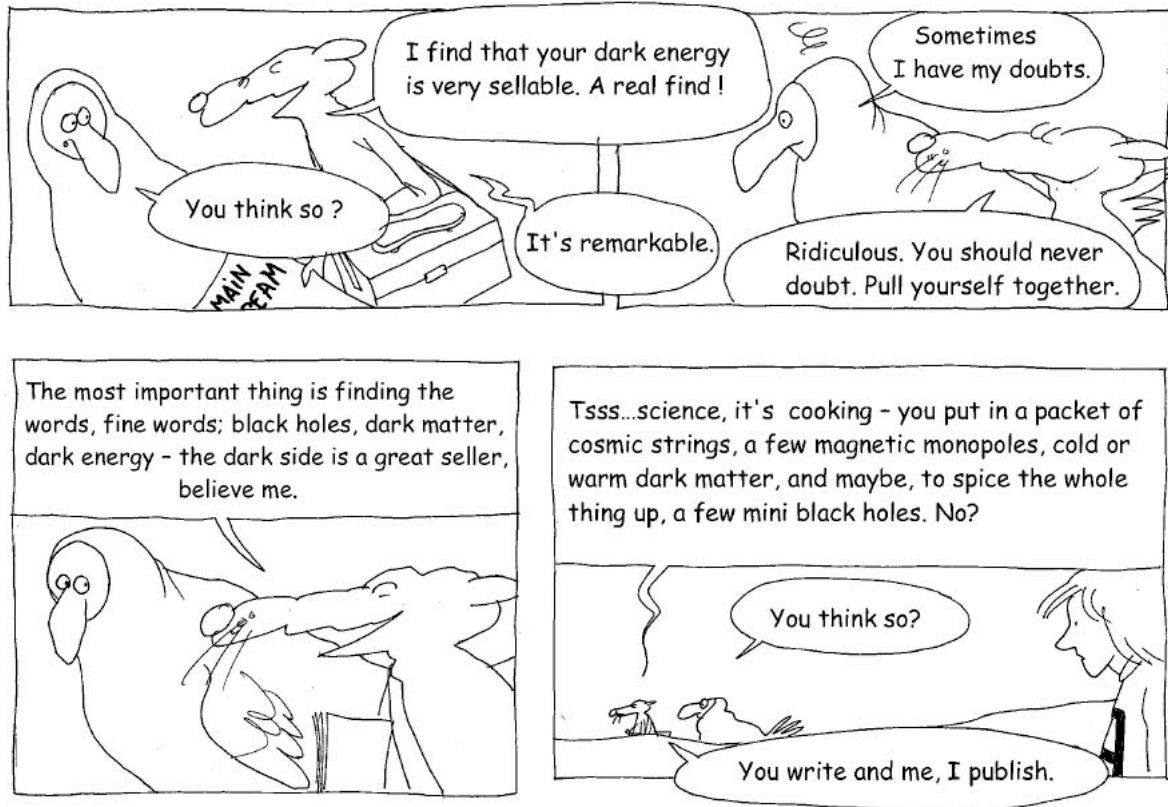

The Janus cosmological model provides an alternative explanation. The expansion is mastered by the negative content. Comparison to available (740 supernovae) is very good. The model challenges the so-called Concordance model (cold dark matter plus effect of the cosmological constant : many free parameter to be adjusted to fit data).

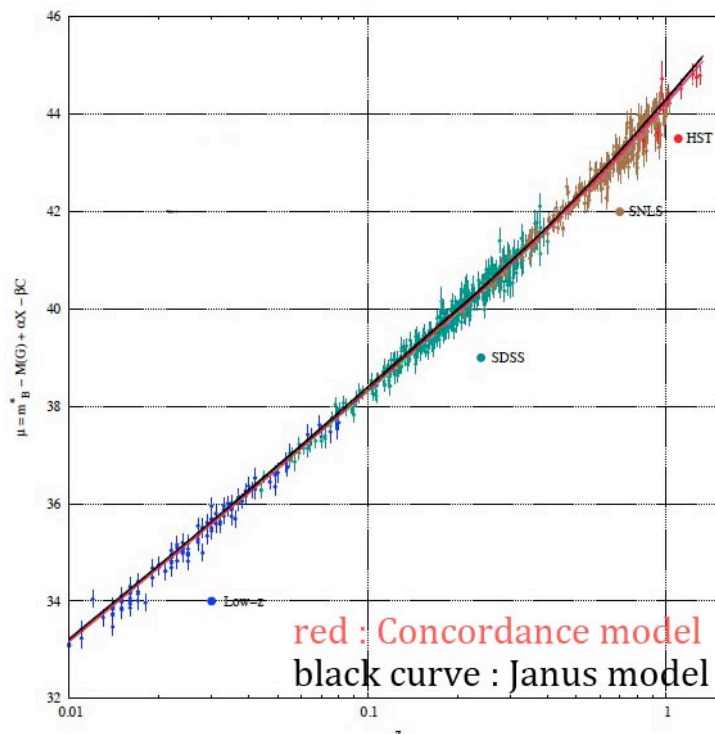
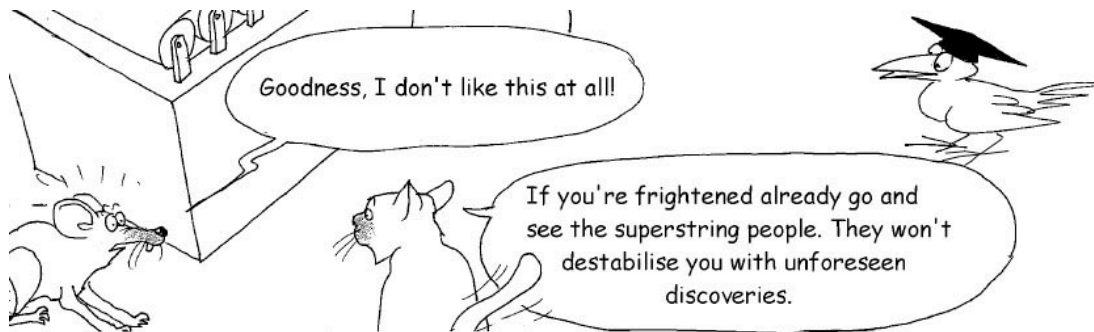

Fig.28 : The JCM model fits quite well the available data



Last work : the radiative era (2016)

This description completes the model. Here we have two sets of « variable constants », for positive and negative masses.

$$\{ c^{(+)}, G^{(+)}, m^{(+)}, h^{(+)}, e^{(+)}, \mu^{(+)} \} \text{ and } \{ c^{(-)}, G^{(-)}, m^{(-)}, h^{(-)}, e^{(-)}, \mu^{(-)} \}$$

We shift to the new set of equations, describing the coupled radiative eras.

$$R_{\mu\nu}^{(+)} - \frac{1}{2} R^{(+)} g_{\mu\nu}^{(+)} + \Lambda^{(+)} g_{\mu\nu}^{(+)} = +\chi \left[T_{\mu\nu}^{(+)} + \sqrt{\frac{g^{(-)}}{g^{(+)}}} T_{\mu\nu}^{(-)} \right]$$

$$R_{\mu\nu}^{(-)} - \frac{1}{2} R^{(-)} g_{\mu\nu}^{(-)} + \Lambda^{(-)} g_{\mu\nu}^{(-)} = -\chi \left[\sqrt{\frac{g^{(+)}}{g^{(-)}}} T_{\mu\nu}^{(+)} + T_{\mu\nu}^{(-)} \right]$$

We build again an exact solution. The system appears immediately unstable. The expansion curves depart each from the other :

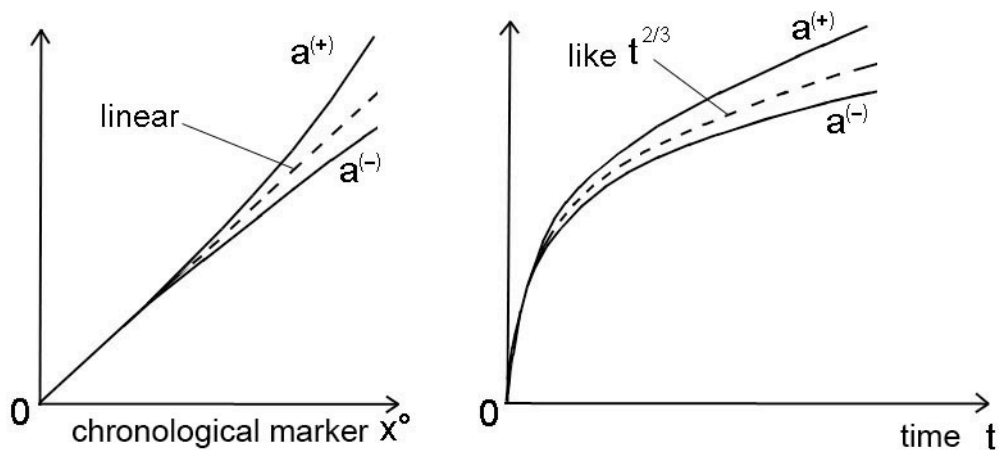

Fig.29 : The two scale factors depart each from the other

Similarly we get joint evolutions of the two speeds of light.

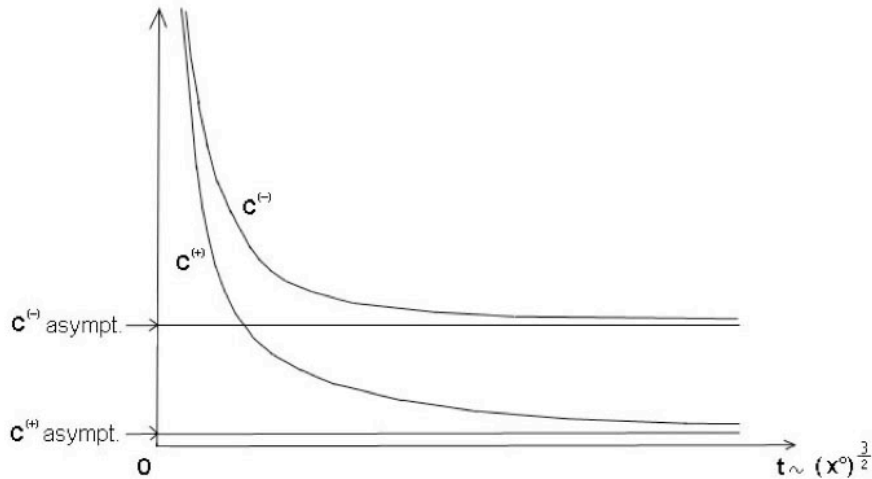

Fig.30 : The two speeds of light depart each from the other

If $\{ \xi_1, \xi_2, \xi_3 \}$ are the adimensional space coordinates (of the manifold M4), considering two distinct points A and B, with $\xi_{2A} = \xi_{2B}$; $\xi_{3A} = \xi_{3B}$ we have the two distances :

$$L^{(+)} = a^{(+)} (\xi_{1B} - \xi_{1A}) > L^{(-)} = a^{(-)} (\xi_{1B} - \xi_{1A})$$

The ratio $\frac{a^{(+)}}{a^{(-)}} > 1$ will be determined from the comparizon of 3D simulations to all available observational data. The ratio $\frac{c^{(-)}}{c^{(+)}} > 1$ is deduced from $a^{(+)} c^{(+)^2} = a^{(-)} c^{(-)^2}$

It shows that if some unknown technology would make possible to invert the mass of a craft, a given interstellar distance could be spanned in a time acceptable for human passengers.

What about opposite arrows of time ?

This was a puzzling remaining question until I discovered the work of the french mathematician Jean-Marie Souriau. A strange man. Like living on a desert island he built his own scientific world and published several books, in french. You may discover him on the following video :

<http://www.jmsouriau.com/Videos/JMSouriau.mp4>

He founded [symplectic geometry](#) with two other mathematicians, [Bertram Kostant](#) and [Alexander Kirillov](#)



B.Kostant



A.Kirillov

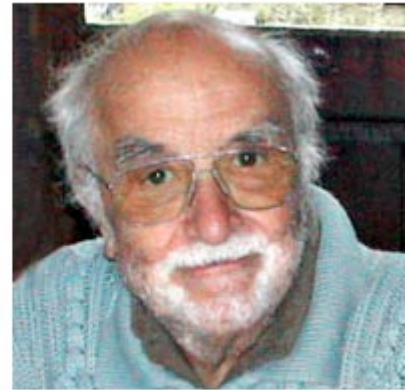

J.M.Souriau

During all his life Souriau never spoke a word of english. Personally I think Souriau bought a major contribution to mathematical physics, but suprizingly his work is not mentionned :

https://en.wikipedia.org/wiki/Mathematical_physics

He published, in french, a book devoted to his theory of Dynamical systems⁵, which was published in english, word to word, 28 years later⁶ (...).

I has been very difficult to me to enter this mathematical labyrinth. Souriau, retired, was my neighbour. He developped a great patience to explain his work to me. The link to physics seems to me very important.

In mathematics a « group » is a mathematical tool you can use to transport mathematical objects. For example with the elements the Euclid's group (translations + rotations + symmetries) you can « transport » geometrical objects like points, straight lines, planes, spheres, cylinders. All are invariant through the action of elements forming « subgroups ». For example an object with rotational symmetry is invariant through the action of a subgroup which is the set of the rotation around an axis.

A sphere is invariant through the subgroup of rotations around a point. And so on.

But this provides a powerful idea. We can define the 3D geometric objets as being invariant trough the action of a given subgoup. Thus the sphere becomes the geometrical objects that is invariant through the action of three-dimensional rotations around a point.

Notice that this is *different* from the classical following definition :

⁵ J.M.Souriau : Structure des Systèmes Dynamiques. Editions Dunod, France, 1970.

⁶ J.M.Souriau : Structure of Dynamical Systems. Ed. Birkhauser 1997

- *A sphere is composed by the set of points whose distance with respect to a given fixed point is the same, and is called « radius ».*

We are familiar with transformations like translations, rotations, symmetries. But where do they come from ?

They form a set of transformations which keep the lengths invariant in an Euclidean space so that we say that they form its *isometry group*.

What about 4D spaces ? In the Minkowski space time the (elementary) length is defined by (let's take $c = 1$)

$$ds^2 = dt^2 - dx^2 - dy^2 - dz^2$$

Does a group exists which preserves such puzzling length ?

Yes, it is called the Poincaré's group⁷.

But what are the « geometrical objects » which inhabit this 4D-space ?

The 3D-Euclidean group's inhabitants are steady objects, like lines.

The Minkowski space contains ... paths, trajectories. A physicist would say that such lines must be oriented from the past to the future.

We only consider straight paths (which are geodesics of such space).

Given a path in that space, an element of the group will transform such path in another one.

In the Euclidean paths we considered geometrical objects. Using the tool of the « Euclid's group » we discovered a system of classification of peculiar geometric inhabitants of such space, which formed classes of objects.

Using the dynamic group of Poincaré we can define *classes of movements*. And there is the fundamental idea of Souriau :

- *A particle corresponds to a peculiar class of movements.*

He used to say :

- *Tell me how you move and I will tell you **what** you are.*

In effect, what is a particle like an electron ? Just something that moves that way.

The theory of dynamic groups brings a classification of particles as a classification of movements. From the Poincaré's group, two classes of movements appear :

- particle with zero mass (photons and neutrinos, if we assume they don't own one)
- massive particles

⁷ It preserves the length $E^2 - p^2$ of the vector « Energy-impulsion »

Such particles own no electric charge.

Let's go back to the Euclid's group as defined by the Euclidean metric

$$ds^2 = dx^2 + dy^2 + dz^2$$

Keep away any intuition, any image. A mathematician can build its isometry group, the set of transformations which preserves this length. This confirms the experience. The physicist may transport physical object through translations and rotations. .

Then a surprise arises :

The mathematician shows that if one consider a corkscrew, some elements of the group can transform it into its enantiomorphic brother :



Fig.31 : Enantiomorphic corkscrews

This transformation is definitively not physical. In the ordinary world only one kind of corkscrew does exist: the right handed corkscrew. We only find the other one in a different world, the joke chop's world.

We live in the « serious world », not in the « joke chop's world ». Thus the approach « group » makes us to discover the possible existence of exotic objects.

Same thing for the Poincaré's group. Similar analysis provides two sets of movements :

- *orthochronic movements (from past to future)*
- *antichronic movements (from future to past)*

In a very serious world one could ask if enantiomorphic corkscrews do exist.

Similarly, physicists can ask if antichronic movements correspond to something real.

This study was carried out by Souriau in 1970 and provided what I consider as a fundamental theorem :

- *Time inversion goes with energy and mass (if the object owns one) inversion*

In a word :

- *The antichronic movement of a photon corresponds to a negative energy photon.*

- *The antichronic movement of a mass m corresponds to a negative mass (and negative energy) particle.*

Extension of Souriau's work

I have extended Souriau's work, shifting to a Kaluza five-dimensional space, as defined by its metric :

$$ds^2 = dt^2 - dx^2 - dy^2 - dz^2 - d\zeta^2$$

I built a subgroup of its isometry group and classified all possible (geodesic) movements. In addition I assumed the fifth dimension to be closed. This « world » inherits the properties of the Poincaré's group. The movements are splitted into orthochronic and antichronic movements. But, among those two sets we find an additional classification, with respect to the closed fifth dimension :

- *movements with a positive increment $d\zeta > 0$*
- *movements with a negative increment $d\zeta < 0$*

This is a new symmetry. What is the corresponding object ?

Antimatter

Consider the movement of a neutral particle in Minkowski space-time that is compacted into a straight line, time-oriented.

We add the closed dimension (fiber bundle) so that the movement is inscribed on a cylinder :

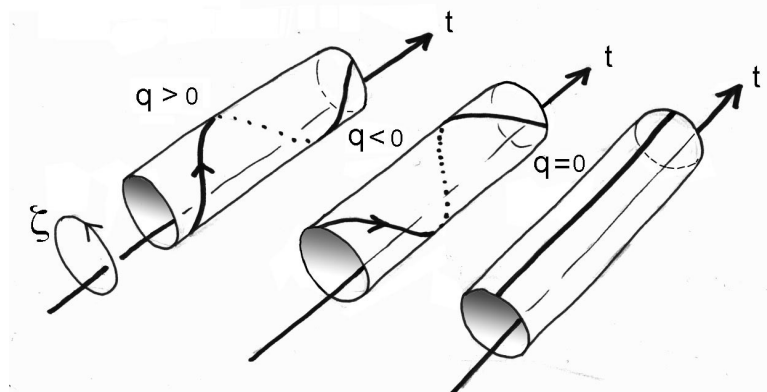

Fig.32 : Geometric representation of matter-antimatter duality

The figure shows the geometrical meaning of the electric charge and the geometric transcription of the matter-antimatter duality, which is nothing but the inversion of fifth dimension in a five dimensional Kaluza space-time.

This analysis starts from the action of the group on its momentum. It refers to symplectic geometry, that requires an even number of coordinates.

By the way Souriau's method of geometric quantification is based on the closure of the fifth dimension (mathematicians call it *compact* dimension). Kaluza space have a odd number of coordinates (five). In our mind that work is the standing point of a generalization of the theory to a complex Kaluza space, but this is out of the scope of the present paper.

The analysis from Kaluza space can be extended adding other closed dimensions : $\{ \varsigma_1, \varsigma_2, \varsigma_3 \dots \}$, with new additional possible translations along those extra dimensions. Then the famous theorem of Emmy Noether produces an equivalent number of invariant scalars, which become the quantum charges $\{ q_1, q_2, q_3 \dots \}$, the electric charges being one of those. As a wellknown feature: the matter antimatter duality goes with the inversion of all those quantum charges (and inversion of all closed additional dimensions).



[Emmy Noether](#) 1882-1935

This general study provides a classification of particles. They are two sets :

- *The orthochronic (positive energy and positive mass if the win) particles*
- *The antichronic (negative energy and negative mass if the win) particles*

Among the two the matter-antimatter duality holds.

We know that the photon is identical to its antiparticle (because all its quantum charges are zero).

Thus, we find :

- *Positive energy photons*
- *Negative energy photons*

The matter antimatter symmetry is also called C-symmetry (charge conjugation)

In the Euclid's three dimensional space we evoked the symmetry that transforms any object into an enantiomorphic, mirror-symmetrical object. Physicists call it P-symmetry (P for « parity » right-left symmetry).

- *Among particles we find their P-symmetrical.*

But what could be the P-symmetrical of a photon ?

Souriau was the first to give the spin a pure geometrical status. The photon owns a spin. Its inversion corresponds to the *polarization phenomenon*.

- The T-symmetrical of a massive particle is the same particle with inversed mass

About the CPT theorem

This famous theorem says that the CPT symmetrical of a particle is identical to that particle.

C : inversion of the quantum charges (and electric charge)

P : right-left symmetry

But T-symmetry implies the inversion of the mass and energy !?!?

According to such extension of dynamic group's theory the CPT symmetrical of a particle should correspond to the same particle, plus the inversion of its mass and energy.

This contradicts the well-known CPT theorem

(a « theorem for physicists » Sourau used to say)

I had to look at the basis of such theorem, the Quantum Theory of Fields. So I bought the bible in the field⁸. Pages 74-76 we find a section devoted to « Space inversion and Time-Reversal ».

In Quantum Mechanics thing depend on the structure of « operators ». So that we find P and T operators.

⁸ S.Weinberg : The Quantum Theory of Field, Cambridge University Press, 2005 edition

In dynamical groups' theory these operators are real, so that a T-inversion goes with the inversion of energy. In Quantum Mechanics operators become complex so that they may be

unitary – anti-unitary

linear – antilinear

If the time-inversion T would be unitary and linear, T-inversion would create negative energy states.

We read, page 76 (we quote) :

- There are no states of negative energy. If we supposed that T is linear and unitary then we get the disastrous conclusion that for any state Ψ of energy E there is another state $T^{-1}\Psi$ of energy $-E$. To avoid it we are forced here to conclude that T is *antilinear and antiunitary*.

Until the discovery of the acceleration of the universe nothing in physics indicated that negative energy would be present somewhere. But this acceleration implies the action of negative pressure. A pressure is a density of energy per unit of volume.

So that this question must be reconsidered

Two kinds of antimatters

The antimatter we produce in labs is C-symmetrical of the matter.

We suggest to call it « Dirac-antimatter ».

Dynamic groups theory shows that CPT-symmetry refers to negative mass matter. In this negative world electrons have a negative mass, but a positive charge. Protons with negative mass have a negative electric charge.

$C \times CPT = PT$ -symmetry gives negative mass antimatter.

We suggest to call it « Feynman-antimatter ».

In effect Richard Feynman suggested that an electron, cruising backwards in time and observed through a mirror (P-symmetry) would behave like a positron.

We have to add « with negative mass ».

In the negative world the positron owns a negative mass, but a positive electric charge.

All that couples to the [Gbar experiment](#), at CERN, where researchers will test the behaviour of antimatter in the gravitational of the Earth.

I predict that such C-symmetrical antimatter will fall down

What about the primeval antimatter ?

We can go back to Andrei Sakharov's schema. His so-called twin universe corresponds to our negative sector, to the world of negative energy and negative mass (if the own one) particles. So that we can suggest the following scenario :

The rate of production of positive mass baryon from positive energy quarks is higher than the rate of production of positive mass antibaryons from positive energy antiquarks.

Inverse situation among the negative energy particles.

After annihilations we get :

- positive energy photons
- a small reliquat of positive mass matter
- the corresponding reliquat of positive energy antiquarks, ratio 3/1
- no positive mass antimatter

On the other hand :

- negative energy photons
- a small reliquat of negative mass antimatter
- the corresponding reliquat of negative energy quarks, ratio 3/1
- no negative mass matter

As opposite energy and negative energy particles do not interact, the negative mass antimatter cannot be evidenced in labo. Moreover it is located between galaxies and at the center of the big voids of the very large structure of the universe.

What about the so-called initial singularity ?

The existence or non existence of singularities in physics is a matter of belief. Personally I tend to think that Nature hosts no singularities. In a paper published in 2014 in Modern Physics Letters A [13] we have showed how the so-called « central singularity » of so-called « black holes » could be eliminated by a simple change of coordinate, so that it is not a *true singularity*, but a *coordinate singularity*. In addition this paper suggests how mass inversion could be naturally achieved in the universe.

Looking back to the Sakharov's model we can figure a link between the two twin universes, without singularity :

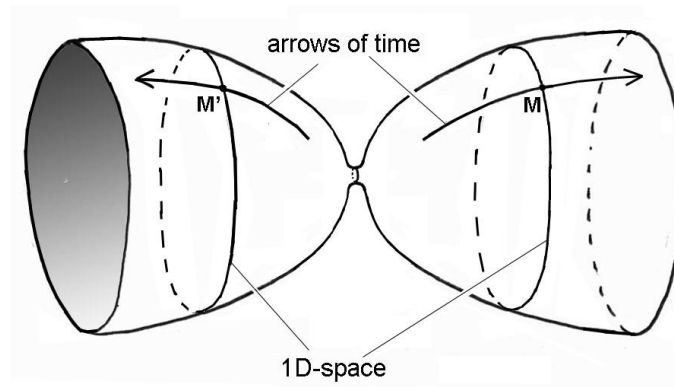

Fig.33 : 2D didactic image of the Sakharov's model, without singularity

With a Big Bang singularity the Janus model could be figured as :

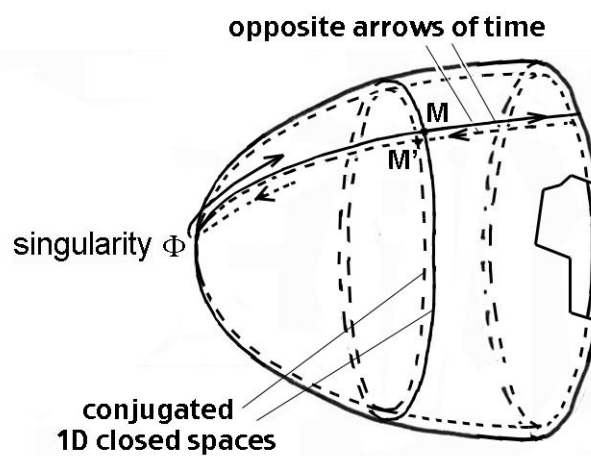

Fig.34 : 2D didactic image of Janus model with singularity

Without singularity :

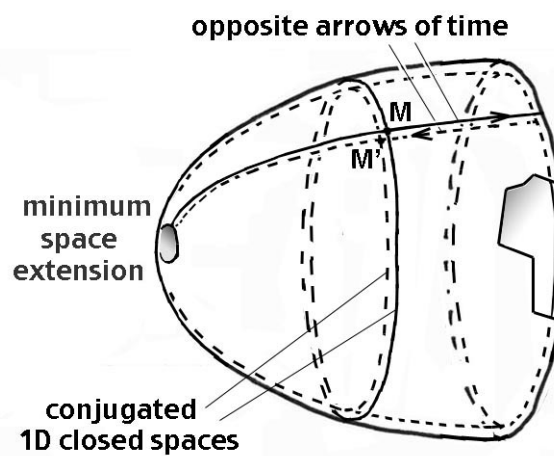

Fig.35 : 2D didactic image of Janus model without singularity

The two 5D folds are linked by a 4D structure. Thus we have a dimensional degeneracy. One dimension must disappear : the one which has no symmetry equivalence in the folds. Check :

- Symmetry $x \rightarrow -x$ holds in both folds (P-symmetry)
- Symmetry $y \rightarrow -y$ holds in both folds (P-symmetry)
- Symmetry $z \rightarrow -z$ holds in both folds (P-symmetry)
- Symmetry $\varsigma \rightarrow -\varsigma$ holds in both folds (C-symmetry)

Thus the symmetry degeneracy is about the t coordinated and the metric of th linking structure is :

$$ds^2 = -dx^2 - dy^2 - dz^2 - d\varsigma^2$$

It is euclidean with imaginary length.

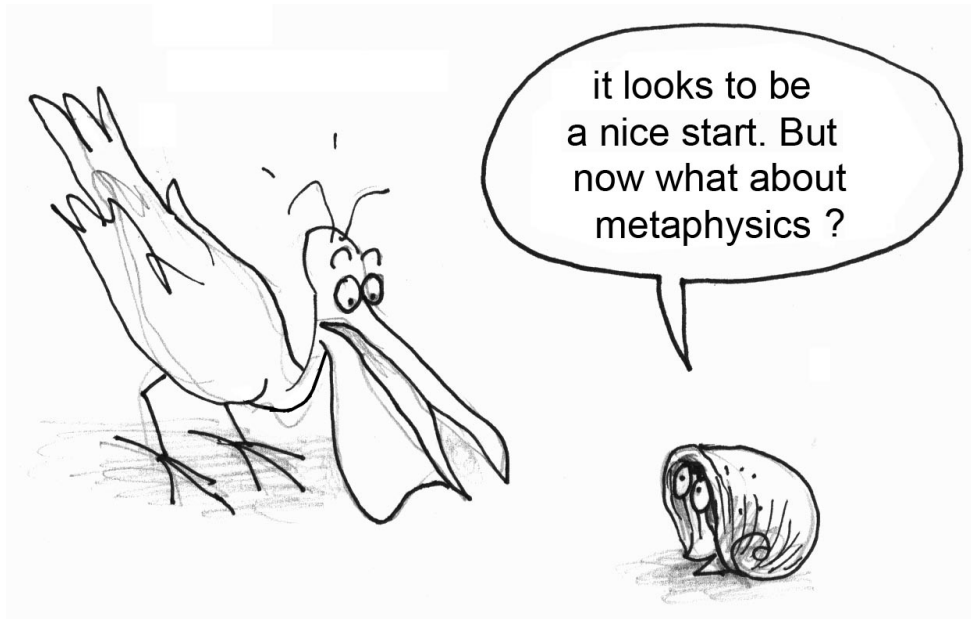

References

[1] A.D.Sakharov, ZhETF Pis'ma 5 : 32 ; JETP Lett. 5 : 24 (1967)

[2] A.D.Sakharov , ZhETF Pis'ma 76 : 1172 (1979) ; JETP 49 : 594 (1979)

[3] A.D.Sakharov , (1980). Cosmological Model of the Universe with a Time Vector Inversion. ZhETF (Tr. JETP 52, 349-351) (79): 689-693

[4] J.P.Petit, Univers Enantiomorphes à flèches du temps opposées. CRAS (French

Comptes Rendus at the Academy of Science of Paris) 1977, math,t.284,pp.1217-°-122.
 ("Enantiomorphic universes with opposite time arrows").

[5] J.P. Petit (May 23, 1977). "Enantiomorphic universes with opposite time arrows".
 Comptes rendus de l'Académie des Sciences 263: 1315–1318. Paris: French Academy of
 Sciences.

[6] J.P. Petit (June 6, 1977). Univers en interaction avec leur image dans le miroir du
 temps.("Universes interacting with their opposite time-arrow fold"-). Comptes rendus de
 l'Académie des Sciences 284: 1413–1416. Paris: French Academy of Sciences..

[7] J. P. Petit, Nuovo Cimento B. The missing mass problem. **109**, 697 (1994).

[8] J.P.PETIT : Cosmological model with variable velocity of light. Modern Phys Letters
 A3, 1988, pp. 1527

[9] J.P.PETIT, Twin Universe Cosmology, Astrophys. and Sp. Science, **226**, 273-307, 1995

[10] J.P.PETIT, P.MIDY & F.LANDSHEAT : Twin matter against dark matter. Intern. Meet.
 on Astrophys. and Cosm. "Where is the matter ? ", Marseille 2001 june 25-29

[11] Koki Izumi, Chizaki Hagiwara, Koki Nakajima , Takao Kitamura and Hideki Asada :
 Gravitational lensing shear by an exotic lens with negative convergence or negative
 mass. Physical Review D **88**, 024049 (2013)

[12] El-Ad H. , Piran T. (1997) Astrophys. J.

[13] J.P.Petit & G.D'Agostini : Cancellation of the singularity of the Schwarzschild
 solution with natural mass inversion process. Mo. Phys. Lett. A vol. 30 n°9 2015